

Inverter User Manual

Table Of Contents

1.Information on this Manual	01
1.1 Validity	01
1.2 Scope	01
1.3 Target Group	01
1.4 Label Description	01
1.5 Safety Instructions	02
2.Introduction	03
3. Installation	04
3.1 Unpacking and Inspection	04
3.1.1 Open-box Inspection	04
3.1.2 Installation Tools	04
3.2 Mounting Unit	04
3.3 AC Input / Output Connection	06
3.4 PV Connection	09
3.5 Battery Connection	11
3.5.1 Lead-acid Battery Connection	11
3.5.2 Lithium Battery Connection	13
3.6 Final Assembly	14
3.7 Smart Communication Stick Connection(Optional)	14
4. Operation	15
4.1 Power ON/OFF	15
4.2 Operation and Display Panel	15
4.2.1 LCD Display Icons	17
4.2.2 LCD Setting	20
4.3 Display Information	31
5. Fault Reference Code	33
6. Alarm Reference Code	36
7. Battery Equalization	38
8. Trouble Shooting	40

1. Information on this Manual

1.1 Validity

This manual is valid for the following devices:

- Solar inverter

1.2 Scope

This manual describes the assembly, installation, operation and of this unit. Please read this manual carefully before installations and operations.

1.3 Target Group





This document is intended for qualified persons and end users. Tasks that do not require any particular qualification can also be performed by end users. Qualified persons must have the following skills:

- Knowledge of how an inverter works and is operated
- Training in how to deal with the dangers and risks associated with installing and using electrical devices and installations
- Training in the installation and commissioning of electrical devices and installations
- Knowledge of the applicable standards and directives
- Knowledge of the compliance with this document and all safety information



1.4 Label Description

In order to ensure the user's personal safety when using this product, the inverter and manual provides relevant identification information and uses appropriate symbols to alert the user, who should carefully read the following list of symbols used in this manual.

Labels on Inverter

	CAUTION Do not disconnect under load!
	Danger: High Voltage! Danger: Electrical Hazard!
	Start maintaining the INVERTER at least 5 minutes after the INVERTER disconnected from all external power supplies.
	Read instructions carefully before performing any operation on the INVERTER.
	Grounding: The system must be firmly grounded for operator safety.

Labels in the documentation

 WARNING!	A high level of potential danger, which, if not avoided, could result in death or serious injury to personnel.
 CAUTION!	A moderate or low level of potential danger, which, if not avoided, could result in moderate or minor injuries to personnel. In some bad situation, it could result in death or serious injury to personnel.

1.5 Safety Instructions



WARNING!

This chapter contains important safety and operating instructions.

Read and keep this manual for future reference.

01. Please be clear which kind of battery system you want, lithium battery system or lead-acid battery system, if you choose the wrong system, energy storage system can't work normally.
02. Before using the unit, read all instructions and cautionary marking on the unit, the batteries and all appropriate sections of this manual. The company has the right not to quality assurance, if not according to the instructions of this manual for installation and cause equipment damage.
03. All the operation and connection please professional electrical or mechanical engineer.
04. All the electrical installation must comply with the local electrical safety standards.
05. When install PV modules in the daytime, installer should cover the PV modules by opaque materials, otherwise it will be dangerous as high terminal voltage of modules in the sunshine.
06. CAUTION - To reduce risk of injury, charge only deep-cycle lead-acid type rechargeable batteries and lithium batteries. Other types of batteries may burst, causing personal injury and damage.
07. Do not disassemble the unit. Take it to a qualified service center when service or repair is required. Incorrect re-assembly may result in a risk of electric shock or fire.
08. To reduce risk of electric shock, disconnect all wirings before attempting any maintenance or cleaning. Turning off the unit will not reduce this risk.
09. NEVER charge a frozen battery.
10. For optimum operation of this inverter, please follow required spec to select appropriate cable size. It's very important to correctly operate this inverter.

11. Be very cautious when working with metal tools on or around batteries. A potential risk exists to drop a tool to spark or short circuit batteries or other electrical parts and could cause an explosion.
12. Please strictly follow installation procedure when you want to disconnect AC or DC terminals. Please refer to INSTALLATION section of this manual for the details.
13. GROUNDING INSTRUCTIONS -This inverter should be connected to a permanent grounded wiring system. Be sure to comply with local requirements and regulation to install this inverter.
14. NEVER cause AC output and DC input short circuited. Do NOT connect to the mains when DC input short circuits.
15. Make sure the inverter is completely assembled, before the operation.

2.Introduction

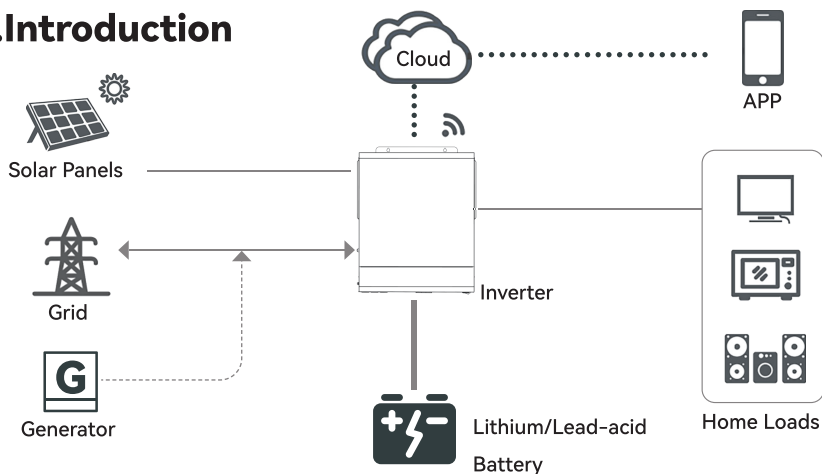

Solar Energy Storage System

This is a multifunctional solar inverter, integrated with a MPPT solar charge controller, a high frequency pure sine wave inverter and a UPS function module in one machine, which is perfect for off grid backup power and self-consumption applications. This inverter can work with or without batteries.

The whole system also need other devices to achieve complete running such as PV modules, generator, or utility grid. Please consult with your system integrator for other possible system architectures depending on your requirements. The WiFi module is built-in or plug-and-play monitoring device to be installed on the inverter. With this device, users can monitor the status of the PV system from the mobile phone or from the website anytime anywhere.









3. Installation

3.1 Unpacking and Inspection

3.1.1 Open-box Inspection

Products have been strictly tested before leaving the factory. Please sign for them after inspection. If the product is damaged, please contact the local distributor. Please open the box to check whether the outer packaging is intact or damaged, whether the internal equipment is damaged.

3.1.2 Installation Tools

Installation Tools	Multi-meter 	Protective gloves 	Insulated anti-smashing shoes 
	Safety glasses 	ESD wrist strap 	Hammer drill 
	Electric screwdriver 	Cross screwdriver 	Rubber mallet 
	Spirit level 	Wire cutter / stripper 	Terminal crimping tool 

3.2 Mounting Unit

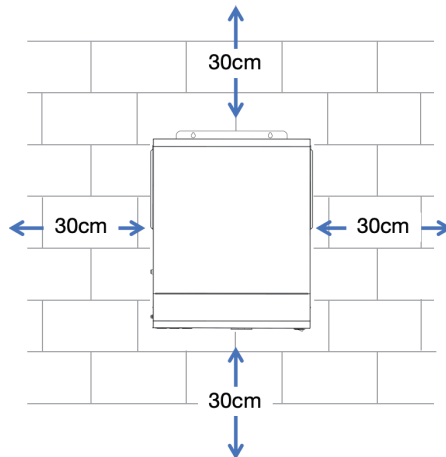

Consider the following points before selecting where to install:

- Do not mount the inverter on flammable construction materials.
- Mount on a solid surface.
- Install this inverter at eye level in order to allow the LCD display to be read at all times.
- The ambient temperature should be between -10°C and 60°C to ensure optimal operation.
- The recommended installation position is to be adhered to the wall vertically.
- Be sure to keep other objects and surfaces as shown in the diagram above to guarantee sufficient heat dissipation and to have enough space for removing wires.



WARNING!

Inverter is suitable for mounting on concrete or other non-combustible surface only.

Follow the installation steps:

1. Use $\phi 8$ drilling bit drill holes on the mounting surface. The distance between 2 holes is 160mm. Then insert the expansion screw tube. M6 expansion screw is suggested.

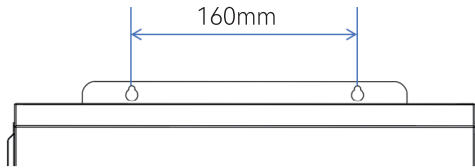

2. Pick up the inverter vertically and align the screws' holes at the top of the inverter with the expansion screw tube already installed on the wall. Fix the inverter on the mounting surface by screws.

Before connecting all wiring, please take off bottom cover by removing four screws as shown below:

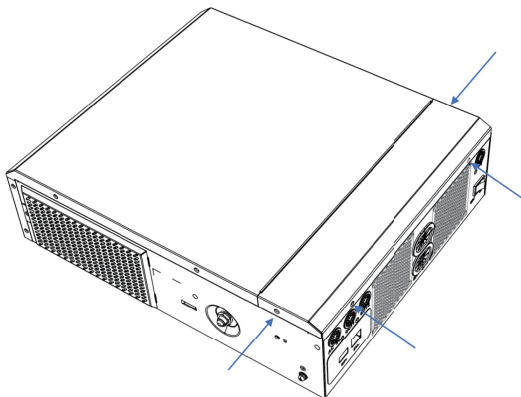

3.3 AC Input / Output Connection



CAUTION!

Before connecting to AC input power source, please install a separate AC breaker between inverter and AC input power source. This will ensure the inverter can be securely disconnected during maintenance and fully protected from over current of AC input. The recommended spec of AC breaker is 40A.



CAUTION!

There are three terminal blocks with 'AC IN', 'AC OUT1', 'AC OUT2' markings. Please do NOT mis-connect input and output connectors.



CAUTION!

Be sure to connect AC cables with correct polarity. If L and N wires are connected reversely, it may cause damage to the inverter. The N wires of input and output must not be connected together, as this may cause damage to the inverter in some condition.



WARNING!

All wiring must be performed by a qualified personnel.



WARNING!

It's very important for system safety and efficient operation to use appropriate cable for AC input connection. To reduce risk of injury, please use the proper recommended cable size as below.

Suggestion for AC input wires

Gauge	Cable (mm ²)
10 AWG	5.26



WARNING!

It's very important for system safety and efficient operation to use appropriate cable for AC output 1/2 connection. To reduce risk of injury, please use the proper recommended cable size as below.

Suggestion for AC output wires

Gauge	Cable (mm ²)
12 AWG	4



WARNING!

Make sure AC power is disconnected before attempting to connect AC power to the unit.

All operations during the electrical connection process, as well as the specifications of cables and components used, must comply with local laws and regulations. The cable color mentioned below is for typical reference.

Please follow below steps to implement AC input (AC IN) connection:

1. Before making AC connection, be sure to open AC circuit breaker first.
2. Remove insulation sleeve 12mm from the head of cables, shorten the conductor part to 10mm. Insert the cable into the tubular terminal. Then use terminal crimping tool make the terminal and cable connected tightly.

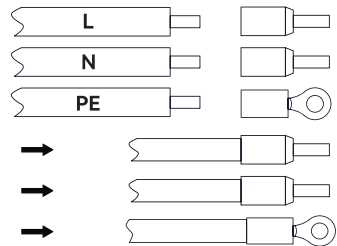

3. Insert AC input cables according to polarities indicated on terminal blocks and tighten the terminal screws. Be sure to connect PE protective cable on the inverter side first.

PE → Protective Earth (yellow-green)

L → LINE (brown or black)

N → Neutral (blue)

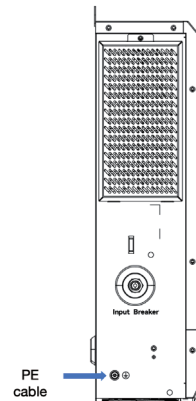

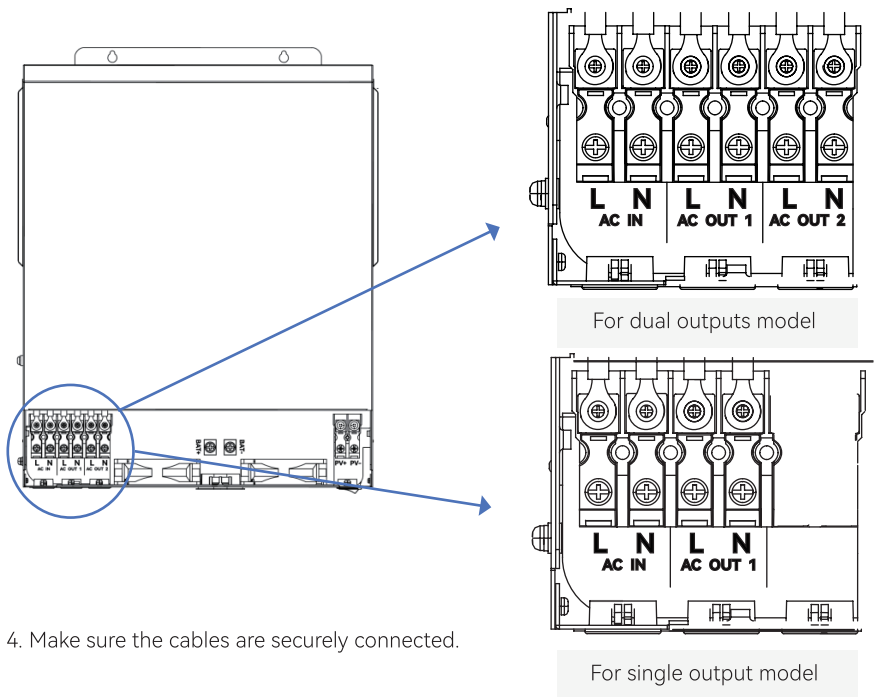

4. Make sure the cables are securely connected.

To implement AC output (OUT1/OU2) connection:

Follow the steps as AC input connection of L (LINE) and N (Neutral) cables.

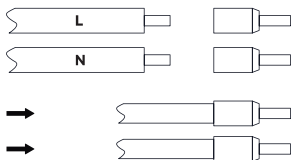

CAUTION!

Appliances such as air conditioner are required at least 2~3 minutes to restart because it's required to have enough time to balance refrigerant gas inside of circuits. If a power shortage occurs and recovers in a short time, it will cause damage to your connected appliances. To prevent this kind of damage, please check with manufacturer of air conditioner that if it's equipped with time-delay function before installation. Otherwise, this solar inverter will trig overload fault and cut off output to protect your appliance but sometimes it still causes internal damage to the air conditioner.

3.4 PV Connection



CAUTION!

Before connecting to PV modules, please install a separate DC circuit breaker between inverter and PV modules.



WARNING!

Do not ground the positive or negative terminals of the PV modules, as this can severely damage the inverter.



WARNING!

Exposure to sunlight can generate lethal high voltages in photovoltaic strings, so strictly adhere to the safety precautions listed in the photovoltaic string and related documents.



WARNING!

Make sure to connect the PV terminals to the corresponding ports on the inverter, as reversing the polarity can damage the inverter.



WARNING!

All wiring must be performed by a qualified personnel.



WARNING!

It's very important for system safety and efficient operation to use appropriate cable for PV module connection. To reduce risk of injury, please use the proper recommended cable size as below. The cable color mentioned below is for typical reference.

Gauge	Cable (mm ²)
10AWG	5.26

PV Module Selection:

When selecting proper PV modules, please be sure to consider below parameters:

1. Open circuit Voltage (Voc) of PV modules not exceeds max. PV array open circuit voltage of inverter.
2. Open circuit Voltage (Voc) of PV modules should be higher than start-up voltage.

Max. PV Array Open Circuit Voltage	500Vdc
Start-up Voltage	80Vdc
PV Array MPPT Voltage Range	60Vdc~450Vdc



WARNING!

Please do not connect any DC switches or AC/DC circuit breakers before completing the electrical connections.

Please follow below steps to implement PV module connection:

1. Before making PV connection, be sure to open DC circuit breaker first.
2. Remove insulation sleeve 12mm from the head of cables, shorten the conductor part to 10 mm. Insert the cable into the tubular terminal. Then use terminal crimping tool make the terminal and cable connected tightly

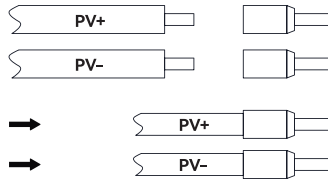

3. Use multi-meter check to ensure the polarities are correct.
4. Insert PV cables according to polarities indicated on terminal block and tighten the terminal screws.

- + → PV+ (red)
- → PV- (black)

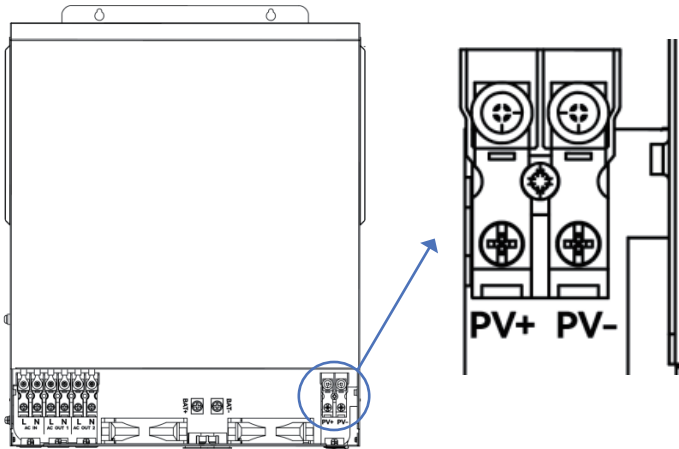

5. Make sure the cables are securely connected.

3.5 Battery Connection

3.5.1 Lead-acid Battery Connection

User can choose proper capacity lead acid battery with a nominal voltage at 48V. Also you need to choose battery type as 'AGM or FLD(flooded)'.



CAUTION!

For safety operation and regulation compliance, it's requested to install a separate DC over-current protector or disconnect device between battery and inverter. It may not be requested to have a disconnect device in some applications, however, it's still requested to have over-current protection installed. The recommended size of protector or disconnect is 150A.



WARNING!

All wiring must be performed by a qualified person.



WARNING!

It's very important for system safety and efficient operation to use appropriate cable for battery connection. To reduce risk of injury, please use the proper recommended cable and terminal size as below. The cable color mentioned below is for typical reference.



WARNING!

Make sure AC power is disconnected before attempting to connect AC power to the unit.

All operations during the electrical connection process, as well as the specifications of cables and components used, must comply with local laws and regulations. The cable color mentioned below is for typical reference.

Recommended battery cable and terminal size:

Gauge	Cable (mm ²)
2 AWG	25

Note: For lead acid battery, the recommended charge current is 0.3C (C≤battery capacity)

Please follow below steps to implement battery connection:

1. Unscrew the pre-fixed screws on battery poles. Prepare 2 DT terminals(it should fit for AWG2 cables).
2. Remove insulation sleeve 12mm from the head of cables, shorten the conductor part to 10 mm. Insert the cable into the DT terminal. Then use terminal crimping tool make the terminal and cable connected tightly.

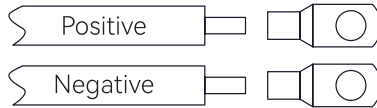

3. Pass the battery cable through the battery installation hole on bottom shell, and tighten the terminal screws. Make sure polarity at both the battery and the inverter/charge is correctly connected and DT terminals are tightly screwed to the battery terminals.

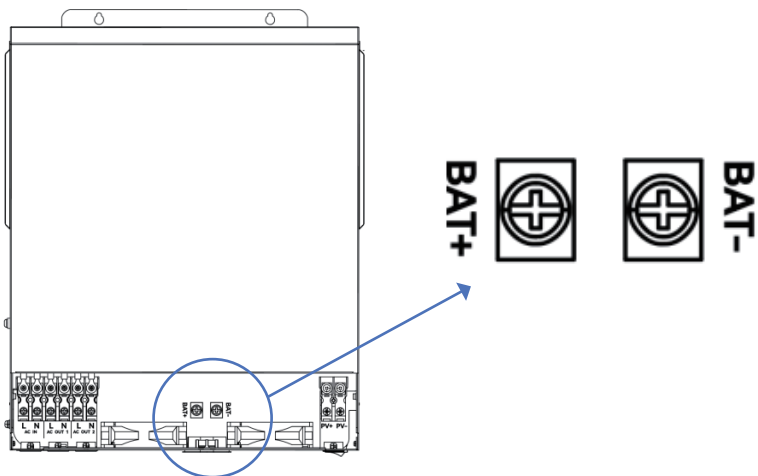

4. Connect all battery packs as units requires. It's suggested to connect at least 200Ah capacity battery.



WARNING! Shock Hazard

Installation must be performed with care due to high battery voltage in series.



CAUTION!

Do not place anything between the flat part of the inverter terminal and the DT terminal. Otherwise, overheating may occur.



CAUTION!

Do not apply anti-oxidant substance on the terminals before terminals are connected tightly.



CAUTION!

Before making the final DC connection or closing DC breaker/disconnector, be sure positive (+) must be connected to positive (+) and negative (-) must be connected to negative (-).

3.5.2 Lithium Battery Connection

If choosing lithium battery for inverter, Please check the compatibility of the protocol first. There are two connectors on the lithium battery, RJ45 port of BMS and power cable.

Please follow below steps to implement lithium battery connection:

1. Follow section 3.5.1 to implement the power cable connection.
2. Connect RJ45 terminal of battery communication cable to BMS communication port of inverter. The communication protocol should be RS485 or CAN.

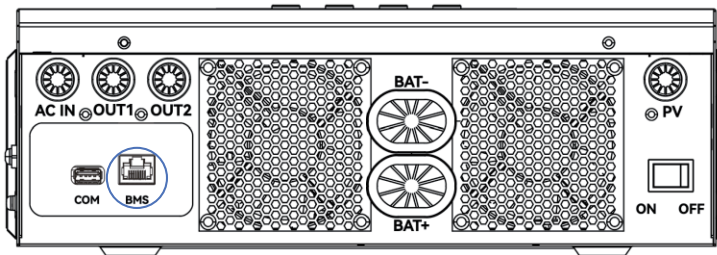

3. Insert the other end of RJ45 (battery communication cable) to battery communication port of lithium battery.

Note: If choosing lithium battery, make sure to connect the BMS communication cable between the battery and the inverter.

Lithium battery communication and setting:

In order to communicate with battery BMS, you should set the battery type to 'LIT' or 'FEL' in Section 4.2.2 Program 17.

Make sure the lithium battery BMS port connects to the inverter is Pin to Pin, the inverter BMS port pin assignment shown as below:

Pin number	BMS port
1	RS485B
2	RS485A
3	-
4	CANH
5	CANL
6	-
7	-
8	-

Communicating with battery BMS in parallel system

If need to use communicate with BMS in a parallel system, you should make sure to connect the BMS communication cable between the battery and one inverter of the parallel system.

3.6 Final Assembly

After connecting all wiring, please put bottom cover back by screwing four screws mentioned in Section 3.2.

3.7 Smart Communication Stick Connection(Optional)

The smart communication stick (WIFI) is used to connect to the cloud platform. Please insert the stick into COM port directly.

Some models support built-in WIFI monitoring function, please check the solar APP quick configuration guide.

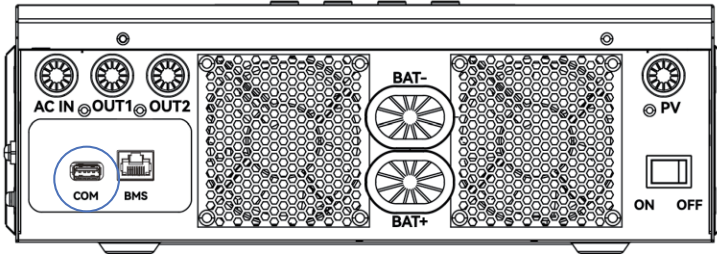

4. Operation

4.1 Power ON/OFF

Once the unit has been properly installed and the batteries are connected well, simply press ON/OFF switch (located on the button of the case) to turn on the unit.

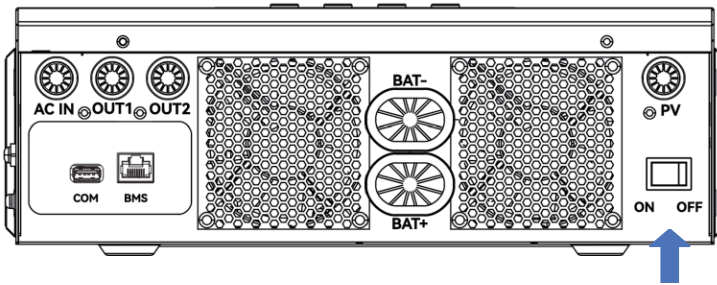

4.2 Operation and Display Panel

The operation and display panel, shown in below chart, is on the front panel of the inverter. It includes four indicators, four function keys and a LCD display, indicating the operating status and input/output power information.

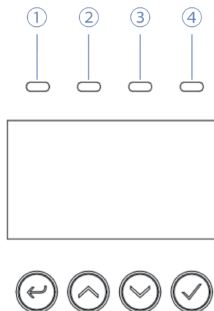

LED Indicator		Messages	
① AC	Status indicator (Green)	Solid On	The mains power is normal and enters the mains power operation.
		Flashing	The mains power is normal, but it has not entered mains power operation.
		Off	The mains power is abnormal.
② Inverter	Invert indicator (Yellow)	Solid On	Output is powered by battery or PV in battery mode.
		Off	Other states.
③ Charging	Charging indicator (Yellow)	Solid On	The battery is in float charging.
		Flashing	The battery is in constant voltage charging.
		Off	Other states.
④ Fault	Fault indicator (Red)	Solid On	Fault occurs in the inverter.
		Flashing	Warning condition occurs in the inverter.
		Off	The inverter is working properly.

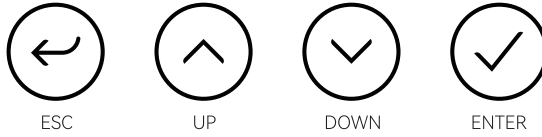







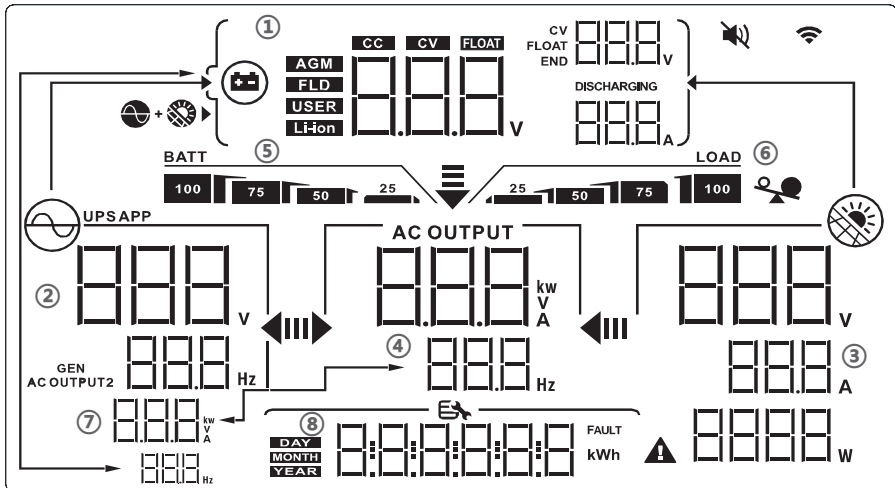











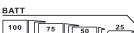
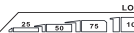

Function Buttons

Button	Description
ESC	To exit setting mode
UP	To go to previous selection
DOWN	To go to next selection
ENTER	To confirm the selection in setting mode or enter setting mode

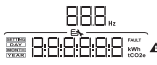





























4.2.1 LCD Display Icons



Display area	Icon	Description
① Battery Information		Battery icon
		Battery type
		Three charging period. The CC icon is illuminated during the constant current charging stage, the CV icon is illuminated during the constant voltage charging stage, and the FLOAT icon is illuminated during the float charging stage.
		Indicate battery voltage
		During the constant voltage charging stage, the CV voltage is displayed and the CV icon is illuminated. During the float charging stage, the float voltage is displayed and the FLOAT icon is illuminated. During the discharge state, the end discharge voltage is displayed and the END icon is illuminated.
		Battery charging/discharging current
② AC Input Information		AC input icon
		UPS or APP input mode When set to GEN input, it displays as APP
		AC input voltage and frequency
③ PV Input Information		PV input icon
		Indicate PV power, PV voltage, PV current, etc.
④ Output Information		Indicate output voltage(V), apparent power (VA or kVA), output active power (W or kW) alternately, switching every five seconds Indicate output frequency
⑤ Battery Capacity		Indicate battery capacity
⑥ Load Capacity		Indicate load capacity
		Over load icon
⑦ AC OUTPUT2 information		Second AC output icon
		Indicate AC output 2 voltage(V)
⑧ Parameter Query, Function Setting or Fault/Alarm Information		Indicate system information; Function setting; Indicate Fault/Alarm



Other Information		Mute
		Wifi connected
		If PV + Grid, the left and right icon light at same time; if only PV, the right icon is only light
		If PV first, the left and right icon light at same time.

For Lead-acid battery, detailed description of battery icon as following:





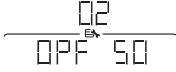



In battery mode, battery icon will present Battery Capacity		
Load Percentage	Battery Voltage	Display
Load >50%	< 44.584V	
	44.584 ~ 46.74V	 
	46.74 ~ 48.896V	  
	> 48.896V	   
50%> Load > 20%	< 47.18V	
	47.18 ~ 49.336V	 
	49.336 ~ 51.492V	  
	> 51.492V	   
Load < 20%	< 48.48V	
	48.48 ~ 50.636V	 
	50.636 ~ 52.792V	  
	> 52.792V	   



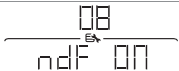



4.2.2 LCD Setting

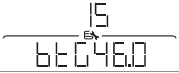
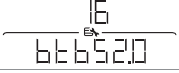

After pressing and holding ENTER button for 2 seconds, the unit will enter setting mode. Press 'UP' or 'DOWN' button to select setting programs. Then press 'ENTER' button to confirm the selection or ESC button to exit.





Program	Description	Setting Option
01	Output voltage	
		230V (default) Adjustable/settable value: 208V, 220V, 230V, 240V
02	Output frequency	
		50Hz(default) Adjustable/settable frequency: 50Hz, 60Hz
03	Output source priority	Grid first (default) <div style="float: right; text-align: center;">  </div>
		<p>Grid provides power to the loads as first priority. Solar power will charge the battery. If solar is not sufficient to charge battery, grid will charge the battery at the same time. If grid is absent and solar is sufficient, solar will power the loads. If grid is absent and solar is not sufficient, solar and battery will power the loads. If grid is absent, solar and battery are not sufficient to power loads at the same time, inverter will go to standby and charge battery.</p>
		Solar first <div style="float: right; text-align: center;">  </div>
		<p>Solar energy provides power to the loads as first priority. If solar energy is sufficient, battery will be charged with solar energy. If solar energy is not sufficient to power all connected loads, Grid will supply power to the loads at the same time. If grid is absent and solar is not sufficient, solar and battery will power the loads. If grid is absent, solar and battery are not sufficient to power loads at the same time, inverter will go to standby and charge battery.</p>





03	Output source priority	PBG priority	$\frac{03}{\text{EA}} \\ \text{OPPPBG}$
		Solar energy provides power to the loads as first priority. If solar energy is sufficient, solar will charge the battery. If solar energy is not sufficient, battery will also supply power. If solar and battery energy are not sufficient, grid will supply power to the loads and solar charges the battery. If battery is charged to be sufficient, solar and battery will power the loads instead of grid. If grid is absent, solar and battery are not sufficient to power loads at the same time, inverter will go to standby and charge battery.	
		MKS	$\frac{03}{\text{EA}} \\ \text{OPPntS}$
		Generator provides power to loads as first priority. When generator, PV, battery all exist, the work mode is as PBG. When generator and battery exist (no PV), the work mode is as GPB. When generator and PV exist (no battery), the work mode is as GPB.	
04	Input mode	APP: Appliance (default)	$\frac{04}{\text{EA}} \\ \text{nOdAPP}$
		Applied to household appliances Typical switching time is 10ms.	
		UPS	$\frac{04}{\text{EA}} \\ \text{nOdUPS}$
		Applied to computer and other devices. Typical switching time is 10ms.	
04	Input mode	GEN	$\frac{04}{\text{EA}} \\ \text{nOdGEN}$
		Applied to connect generator from AC IN port. Typically switching time is 20ms.	
05	Charger source priority	PNG: PV and Grid (default)	$\frac{05}{\text{EA}} \\ \text{CHPPNG}$
		PV and Grid are charged at the same time.	
		OPV: Only PV	$\frac{05}{\text{EA}} \\ \text{CHADPV}$
		Only PV charge.	
05	Charger source priority	PVF: PV first	$\frac{05}{\text{EA}} \\ \text{CHPPVF}$
		If both grid and PV are available, PV charge. If only PV is available, PV charge. If only grid is available, grid charge.	

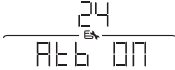

06	Grid charging current	<div style="text-align: center;">  </div> <p>Set charging current for grid chargers. The default setting is 60A. Available options: 2/10/20/30/40/50/60/70/80/90/100/110/120A</p>	
07	Maximum charging current	<div style="text-align: center;">  </div> <p>Set total charging current for solar and grid chargers. The default setting is 100A. Available options: 2/10/20/30/40/50/60/70/80/90/100/110/120A</p>	
08	Menu Default	<div style="text-align: center;">  </div> <p>During setting: Set to ON. If the current page is not on the first page and no operation with 1 minute, the system will return to display the first page. Set to OFF. If the current page is not on the first page and no operation with 1 minute, the system will stay on the current page.</p>	
09	Auto restart when overload occurs	ON(default)	<div style="text-align: center;">  </div>
10	Auto restart when over temperature occurs	ON(default)	<div style="text-align: center;">  </div>
11	Main input cut warning	<div style="text-align: center;">  </div> <p>Enable/Disable Grid or PV loss alarm. The default setting is ON. If the grid input detected lost, the buzzer will sound for 5 seconds. when set to OFF, after the grid input is lost, the buzzer will not sound.</p>	
12	Energy-saving mode	<div style="text-align: center;">  </div> <p>The default setting is OFF. When set to ON, in battery mode, if the load is lower than 25W, the system will stop output for a period then resume. If the load is still lower than 25W, the system will do the loop stop then resume. If the load is higher than 35W, the system will resume continuous normal output.</p>	
13	Overload transfer to bypass	<div style="text-align: center;">  </div> <p>The default setting is OFF. When set to ON, in the case of PBG (PV priority) or MKS (generator priority) mode, if there is an overload, the system will immediately transfer to bypass mode (grid power output, also known as bypass mode).</p>	



14	Silent mode setting		
		<p>Enable/disable buzzer sound. The default setting is OFF. When set to ON, in any situation such as alarms or faults, the buzzer will not sound. This setting can be applied to all modes. Button sound is not effected.</p>	
15	Battery return to grid voltage point		
		<p>When the battery is set to the AGM (Lead Acid Battery Type) or FLD (Flooded Battery Type) mode. The default setting is 46V, and it can be adjusted within a range of [44, 52V].</p>	
		<p>When the battery is set to LIT (Ternary lithium battery). The default setting is 47.6V. It can be adjusted within a range of [40, 50V]. When the battery is set to FEL (Lithium iron battery), the default setting is 49.6V. It can be adjusted within a range of [40, 50V].</p>	
		<p>When the battery is set to the CUS (Customer Setting Type) mode. The adjustable range is [40, 50V]. The default setting is 47.6V, and it can be adjusted within a range of [40, 50V].</p>	
16	Switching back to battery mode voltage points		
		<p>After the battery shuts down due to low voltage, it needs to reach a certain voltage level to restart in battery mode. The value can be set to FUL or battery voltage. If set to FUL, the battery will only recharge to full capacity before it can restart in battery mode.</p>	
		<p>When the battery is set to AGM (Absorbent Glass Mat) or FLD (Flooded) mode, The default setting is 52V. It can be adjusted within a range of [48, 58V].</p>	
		<p>When the battery is set to LIT (Ternary lithium battery). The default setting is 54.4V. It can be adjusted within a range of [46, 58V]. When the battery is set to FEL (Lithium iron battery), the default setting is 53.2V. It can be adjusted within a range of [46, 58V].</p>	
		<p>When the battery is set to CUS (Customer Set Type) mode, The default setting is 54.4V, The voltage range is [46, 58V].</p>	
17	Battery type	AGM(default)	
		Flooded	
		Lithium (Ternary Lithium Battery)	
		FEL (Lithium iron)	
		User-Defined	

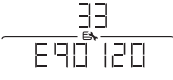
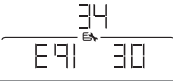

18	Battery low voltage point	<div style="text-align: center;">  </div> <p>Battery low voltage alarm setting.</p> <p>When the battery type is set to LIT, the default setting is 47.6V. The adjustable range for the voltage is [41.2, 50V]. Initial settings for CUS are the same as for LIT.</p> <p>When the battery type is set to FEL, the default setting is 48V. The adjustable range for the voltage is [41.2, 50V].</p> <p>It is not possible to set the battery definition mode to AGM or FLD mode. The default setting is 44V.</p>
19	Battery shutdown voltage point	<div style="text-align: center;">  </div> <p>The battery low voltage shutdown point setting function cannot be adjusted when the battery is defined as AGM or FLD mode. The default setting is 42V.</p> <p>When the battery type is set to LIT , the battery shutdown point can be modified. The default setting is 46V, and the adjustable range is [40, 48V]. Initial settings for CUS are the same as for LIT. When the battery type is set to FEL , the battery shutdown point can be modified. The default setting is 42V, and the adjustable range is [40, 48V].</p>
20	Constant voltage mode voltage point setting	<div style="text-align: center;">  </div> <p>When the battery is defined in AGM or FLD mode, the voltage set point cannot be configured. The default setting for AGM mode is 56.4V, for FLD mode is 58V.</p> <p>When the battery type is CUS, It can be set within the range of [48, 60V] for the constant voltage charging set point. The default setting is 56.4V. It is important to note that the constant voltage set point voltage needs to be higher than the float charge set point voltage.</p> <p>When the battery type is set to LIT, the default setting is 56.4V, and it can be adjusted within the range of [48, 60V]. When the battery type is set to FEL, the default setting is 55.2V, and it can be adjusted within the range of [48, 60V].</p> <p>It is important to ensure that the constant voltage set point voltage is higher than the float charge set point voltage.</p>

21	Floating charge mode voltage point setting	<div style="text-align: center;">  </div> <p>If battery type is AGM or FLD mode, the voltage set point cannot be configured. The default setting is 54V. If the battery type is CUS, the default setting is 55.2V. The setting range is [50, 58V]. If the battery type is LIT, the default setting is 55.2V. The setting range is [50, 58V]. If the battery type is FEL, the default setting is 54.4V. The setting range is [50, 58V].</p> <p>It is important to note that the constant voltage point voltage should always be set higher than the floating charge point voltage.</p>
22	Grid low voltage point setting	<div style="text-align: center;">  </div> <p>If input mode is APP/GEN, Grid low voltage point can be set within a range of 90V to 154V. The default setting is 154V. If input mode is UPS, Grid low voltage point can be set within a range of 170V to 200V. The default setting is 185V.</p>
23	Grid high voltage point setting	<div style="text-align: center;">  </div> <p>If input mode is APP/GEN, Grid high voltage point can be set within a range of 264V to 280V. The default setting is 264V. If input mode is UPS, Grid high voltage point is set as 264V.</p>
24	Automatic turn off backlight	<div style="text-align: center;">  </div> <p>The default setting is ON. If ON, the backlight will turn off after 1minutes of no button operation.</p>
25	Inverter soft start setting	<div style="text-align: center;">  </div> <p>The default setting is OFF. If ON, the inverter output gradually increases from 0 to the target voltage value. If OFF, the inverter output directly increases from 0 to the target voltage value. Setting Condition: It can be set in single-machine operation mode.</p>

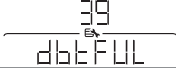

26	Reset factory setting	<div style="text-align: center;">  </div> <p>Restore all settings to factory default values. Before the setting, this interface is displayed as OFF. When set to ON, the system will restore to default settings. After the setting is completed, this interface will display OFF again. The setting can be applied immediately in mains and standby modes, but cannot be set in battery mode.</p>
29	Battery Disconnection Alarm	<div style="text-align: center;">  </div> <p>Enable/Disable battery disconnection alarm. OFF(default). When set to OFF, there will be no battery disconnection alarm when the battery is disconnected.</p>
31	Equalization Voltage Point Setting	<div style="text-align: center;">  </div> <p>The default setting for FEL battery type is 56V, setting range is [48, 60V]. The default setting for AGM/FLD/LIT/CUS battery type is 58.4V, with a configurable range of [48, 60V].</p>
32	Equalization Charging Time Setting	<div style="text-align: center;">  </div> <p>The function can be set as 'OFF' or active. During the equalization stage, the controller will charge the battery as much as possible until the battery voltage rises to the battery equalization voltage. Then, it will adopt constant voltage regulation to maintain the battery voltage. The battery will remain in the equalization stage until the set battery equalization time is reached. The setting range is [5, 900] with 5 minutes for every step. The default setting is OFF.</p>

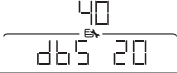
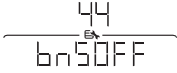
33	Equalization Delay Time Setting	<div style="text-align: center;">  </div> <p>The function can be set as 'OFF' or active. During the equalization stage, if the battery equalization time expires and the battery voltage has not risen to the battery equalization voltage point, the charging controller will extend the battery equalization time until the battery voltage reaches the battery equalization voltage. When the battery equalization delay setting is completed and the battery voltage is still below the battery equalization voltage, the charging controller will stop equalization and return to the floating stage. The default setting is 120 minutes, with a configurable range of [5, 900], and an increment of 5 minutes for each setting.</p>
34	Equalization Interval Time Setting	<div style="text-align: center;">  </div> <p>When the battery connection is detected during the float phase with the equalization mode turned on, the controller will start to enter the equalization phase when the set equalization interval (cell equalization period) is reached. The default setting is 30 days, the settable range is [1, 90], and the increment of each setting is 1 day.</p>
35	Enable Equalization Immediately	<div style="text-align: center;">  </div> <p>The default setting is OFF, and the function is not turned on. If it is set to ON, in the float charging stage when the equalization mode is turned on and the battery connection is detected. The equalization charging is activated immediately, and the controller will start to enter the equalization stage.</p>

36	Grid-tie inverter function	<div style="text-align: center;">  </div> <p>Set whether the inverter is grid fed or not. If the value is 'INT', the inverter can feed to grid according to different output source priority.</p> <p>In PGB mode when battery level is sufficient, as long as grid is connected, PV can feed energy to grid as much as possible and surplus energy of PV charges the battery.</p> <p>In PGB mode when battery level is NOT sufficient, PV charges battery as much as possible and surplus energy of PV feeds to grid.</p> <p>In GPB mode and PBG mode, as long as grid is connected, PV charges battery as much as possible and surplus energy of PV feeds to grid.</p> <p>In MKS mode, inverter does not feed to grid.</p>
37	Max Grid Tie Power	<div style="text-align: center;">  </div> <p>Setting the output power value to grid. The default setting is 6.5kW. The setting range is [0, 6.5]kW. Every setting step is 0.5kW.</p>
38	Battery dual output low voltage shutdown point	<div style="text-align: center;">  </div> <p>When enabled, the secondary output of the inverter is enabled by default. In battery mode, when the battery voltage drops below the set point, the secondary output is turned off. When the battery voltage rises above the set value plus 1V per additional battery cell, the secondary output is turned on.</p> <p>The default setting is 48V, with a configurable range of [44, 60]V. When the set point is higher than the constant voltage charging (CV) point - 1V per cell, the recovery voltage is set to the constant voltage charging point.</p>
39	Battery dual output duration	<div style="text-align: center;">  </div> <p>When enabled, the secondary output of the inverter is enabled by default. In battery mode, when the battery discharge time reaches the set point, the secondary output is turned off.</p> <p>Default setting is OFF, the function is not enabled. The configurable range is [5,900] in minutes.</p> <p>When set to FUL, the secondary output has unlimited output time.</p>

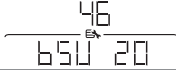
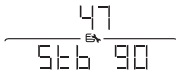
40	Dual output battery mode cut-off SOC	<div style="text-align: center;">  </div> <p>When enabled, the secondary output of the inverter is enabled by default. In battery mode, when the battery SOC is lower than the set value, the secondary output is turned off. After the battery voltage is 5% higher than set value, the secondary output will turn on. The default setting is 20. The setting range is [5, 90] and OFF.</p>
44	BMS Communication Function	<div style="text-align: center;">  </div> <p>The default setting is OFF, and the function is not enabled. When set to a specific BMS protocol, the inverter communicates with the lithium battery BMS through the centralized control board and obtains battery information. If the communication is abnormal after the function is enabled, alarm 56 is generated, and the inverter does not determine the running logic based on the BMS information. CVT: CVTE protocol (485) PYL: PYLON protocol (485 and CAN) GRO: GROWATT protocol (485 and CAN) VOL: VOLTRONIC protocol (485) IRO: China Tower protocol (485) PAR: PACE RTU protocol (485)</p>
45	BMS ID	<div style="text-align: center;">  </div> <p>Setting BMS ID number to communication with. The setting value is AtO or numerical value [0, 15]. Among them, A-F represents 10-15 respectively. The default value is auto (AtO). When set to auto (AtO), system will automatically poll the BMS ID from small to large. When system poll for the first ID with a correct response, it locks the ID and only asks the BMS with that ID.</p>

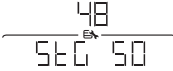
46	Low SOC Shutdown	<div style="text-align: center;">  </div> <p>Set the inverter to shut down when the State of Charge (SOC) of the battery is low.</p> <p>The default setting is 20, with a configurable range of [5, 50]. When the lithium battery SOC reaches the set value in battery mode, the inverter shuts down and generates alarm 68. The alarm 68 is cleared when the SOC returns to the set value + 5%. In standby mode, the inverter can switch to battery mode only when the SOC reaches the set value + 10%. If it does not reach this threshold, alarm 69 is generated. Once the function is enabled, alarm 69 is triggered when the lithium battery SOC reaches the set value + 5%, and it is cleared when it returns to the set value + 10%.</p> <p>It can be set to OFF, in which case the inverter no longer performs shutdown, startup, or alarm operations based on the SOC condition.</p> <p>Once the function is enabled, if a communication abnormality occurs, the inverter no longer operates based on the SOC information and clears the related alarms.</p>
47	High SOC to Battery	<div style="text-align: center;">  </div> <p>Set the SOC value for the inverter to switch to battery mode.</p> <p>The default setting is 90, with a configurable range of [10, 100]. In PBG priority mode, when the lithium battery SOC reaches the set value in normal grid mode, the inverter switches to battery mode. Once enabled, the inverter will only switch to battery mode when the SOC is above the set point and the battery voltage is higher than the voltage point to switch back to battery mode.</p> <p>It can be set to OFF, in which case the inverter no longer switches from grid mode to battery mode based on the SOC condition.</p> <p>Once the function is enabled, if a communication abnormality occurs, the inverter no longer operates based on the SOC information and clears the related alarms.</p>







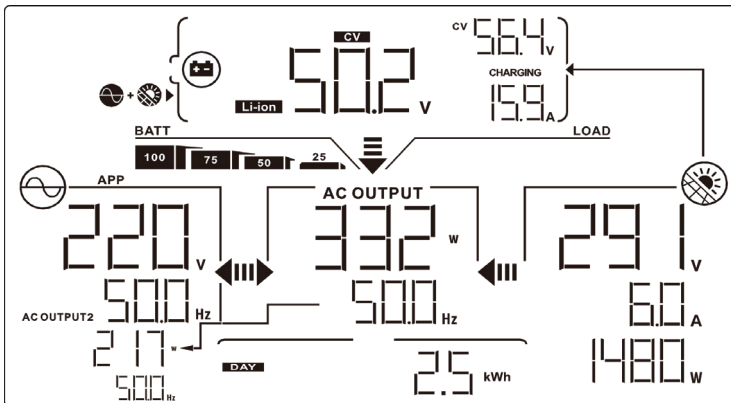

48	Low SOC to Grid	<div style="text-align: center;">  </div> <p>Set the SOC value for the inverter to switch to grid mode. The default setting is 50, with a configurable range of [10, 90]. In PBG priority mode, when the lithium battery SOC reaches the set value in battery mode, the inverter switches to grid mode. Once enabled, the inverter will switch to grid mode when the SOC is below the set point or the battery voltage is lower than the voltage point to switch back to grid mode. It can be set to OFF, in which case the inverter no longer switches from battery mode to grid mode based on the SOC condition. Once the function is enabled, if a communication abnormality occurs, the inverter no longer operates based on the SOC information and clears the related alarms. When this setting is higher than the STB point, STB and STG will no longer take effect after the next activation.</p>
61	Battery Max. Discharge Current	<div style="text-align: center;">  </div> <p>The default setting is OFF. If the current is higher than 140A and the over-current time reaches 1 min, fault 14 will occur and inverter goes into fault mode. When set to a numerical value, it indicates the limitation current value. The setting range is [10, 140A] with a setting step of 5A. If the discharging current is over the limitation, alarm 60 will occur. If the continuous over-current time reaches 5 seconds, fault 14 will occur and inverter goes into fault mode.</p>

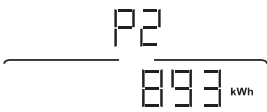
4.3 Display Information

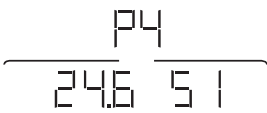
The LCD display information will be switched in turns by pressing 'UP' or 'DOWN' key. If there is no operation for a long time, the daily PV power generation will be displayed at the bottom of the screen. For example the following screen displays 2.5kWh.



The selectable information is switched as below.

LCD display	Information
	Display the daily power generation from solar.
	Display total power generation from solar.
	Display lithium battery voltage and current. Display ERR when BMS communication fails. If BMS function is disabled, the page will not display.
	Display lithium battery temperature and SOC. Display ERR when BMS communication fails. If BMS function is disabled, the page will not display.
	Display lithium battery rated capacity and remaining capacity. Display ERR when BMS communication fails. If BMS function is disabled, the page will not display.
	Display lithium battery maximum charging voltage and minimum discharging voltage. Display ERR when BMS communication fails. If BMS function is disabled, the page will not display.
	Display lithium battery maximum charging current and maximum discharging current. Display ERR when BMS communication fails. If BMS function is disabled, the page will not display.
	Display lithium battery alarm and fault information. Display ERR when BMS communication fails. If BMS function is disabled, the page will not display.
	Display inverter firmware version.

5. Fault Reference Code



Fault display:

Function description: If alarm occurs, Fault indicator flashes and buzzer sounds every one second for 1 minute, then stop. If fault occurs, the fault indicator is always on, the buzzer sounds 10 seconds then stops. System will try restart automatically. If the machine does not work after six times' restart, the machine and LCD display will always in the fault status. You need to completely power off (off the screen) or wait for 30 minutes to restart the machine. The fault LCD display is shown in the figure above. In fault mode fault icon is bright, in alarm state alarm icon is flashing, and contact the manufacturer to troubleshoot the abnormal situation according to the fault information.

Fault: The inverter enters fault mode, with a constant red LED light and LCD displaying a fault code.

Fault code sheet

Fault code	Meaning	Relevant action	Trigger conditions	Resume conditions
1	Bus boost fail	Turn fault mode	Grid soft start process starts but bus voltage does not reach set value	Restore after reaching the set voltage for 15 seconds
2	Bus over voltage	Turn fault mode	Bus voltage is higher than set value	Restore after reaching the set voltage for 15 seconds
3	Bus below voltage	Turn fault mode	Bus voltage is lower than set value	Cannot restore

Fault code	Meaning	Relevant action	Trigger conditions	Resume conditions
4	Battery over current	Turn fault mode	Battery current is higher than set value	Cannot restore
5	System over temperature	Turn fault mode	PFC temperature is higher than set value or fan is not connected	Restore after temperature lower than set value and fan connected for 15 minutes
6	Battery over voltage	Turn fault mode	Battery voltage is higher than set value	Restore after reaching the set voltage for 15 seconds
7	Bus soft start failed	Turn fault mode	Battery soft start process starts but the bus voltage has not reached set value	Restore after reaching the set voltage for 15 seconds
8	Bus short circuit	Turn fault mode	Bus voltage is lower than set value	Cannot restore
9	Inverter soft start failed	Turn fault mode	Inverter soft start process starts but the inverter voltage has not reached set value	Restore after reaching the set voltage for 15 seconds
11	Inverter under voltage	Turn fault mode	The inverter voltage is lower than the set value in battery mode	Restore after reaching the set voltage for 15 seconds

Fault code	Meaning	Relevant action	Trigger conditions	Resume conditions
12	Inverter short circuit	Turn fault mode	Inverter voltage is less than the set value and current is higher than the set value	Restore after reaching the set value for 15 seconds
13	Inverter negative power	Turn fault mode	The inverter power is negative and exceeds the set value for a period of time	Restore after reaching the set value for 15 seconds
14	Over load	Turn fault mode	The load current is higher than the set value	Restore after reaching the set value for 15 seconds
17	Program updating	Turn fault mode	Inverter updating or OTA	Restore after updating
18	PV reverse connection	Turn fault mode	PV reverse connection	Restore after connecting correctly for 15 seconds
26	BMS fault	Turn fault mode	Error code in BMS message.	Restore after BMS fault resolved
29	Inverter load abnormal	Turn fault mode	Abnormal inverter load leads to abnormal voltage	Restore after voltage returning normal for 15 seconds

6. Alarm Reference Code

Alarm: the inverter does not enter the fault mode, LED red light flashing, LCD displays the Alarm code.

ALA 52

Alarm code sheet

Alarm code	Meaning	Relevant action	Trigger conditions	Resume conditions
50	Battery open	Alarm	Battery disconnected for no more than 10 minutes	Restore after battery connected and charging for 2 minutes
51	Battery under voltage	Alarm, battery low voltage shutdown or cannot power on	Battery voltage is lower than BAU set value	Restore after the battery voltage exceeding the BAU set value by 2V
52	Battery low voltage	Alarm	Battery voltage is lower than BAL set value	Restore after the battery voltage exceeding the BAL set value by 2V
53	Battery charge short circuit	Alarm, battery does not charge	Battery voltage is less than 24V and the charging current exists.	Restore after a maximum of 1 minute when the short circuit is eliminated.
56	BMS loss	Alarm	Communication failure after BMS communication function is enabled	Restore after communication function disabled or communication success
58	Fan error	Alarm, fan operation in full speed	No fan speed signal detected	Restore after fan speed signal detected

Alarm code	Meaning	Relevant action	Trigger conditions	Resume conditions
59	EEPROM error	Alarm	EEPROM read/write exception	Can not restore
60	Overload	Alarm	The mains current/ battery discharge current/ load power is higher than the rated value.	Restore after the mains current/battery discharge current/load power is less than the rated value.
62	PV energy weak	Alarm, Turn off the PV output to the load, but keep the PV charging the battery	When the battery is not connected, the bus voltage is lower than the set value	Restore after battery connected or grid connected, or 10 minutes later.
68	Battery under SOC shutdown	Alarm, turn to standby mode	BMS reports SOC lower than BSU set value	Restore after meeting one of the following three conditions: 1. Disable low SOC shutdown function 2. Disable BMS communication function 3. SOC is higher than the set value by 5%
69	Battery below SOC warning	Alarm, if it is in standby mode, it will remain in standby mode.	Lithium battery SOC is lower than set value+5% (grid mode or battery mode), lower than set value+10% (standby mode)	Restore after meeting one of the following three conditions: 1. Disable low SOC shutdown function 2. Disable BMS communication function 3. SOC is higher than the set value by 10%
72	Battery can not startup	Alarm	During standby, battery voltage is lower than the allowed startup voltage	Restore after the battery voltage is higher than the allowed startup voltage
77	Grid power is unstable	Alarm	Lost of grid power three times within 5 minutes	Restore after 5 mins

7. Battery Equalization

Equalization function is added into charge controller. It reverses the buildup of negative chemical effects like stratification, a condition where acid concentration is greater at the bottom of the battery than at the top. Equalization also helps to remove sulfate crystals that might have built up on the plates. If left unchecked, this condition, called sulfation, will reduce the overall capacity of the battery. Therefore, it's recommended to equalize battery periodically.

Note:*Don't activate this mode when using lithium batteries.

- How to Apply Equalization Function

You can enable battery equalization function in monitoring LCD setting Program 32 by setting time, or you can choose immediate equalization on Program 35. Then, you may apply this function in device by either one of following methods:

- 1.Set equalization voltage point on Program 31.
- 2.Set equalization charging time on Program 32.
- 3.Set equalization delay time on Program 33.
- 4.Set equalization interval time on Program 34.
- 5.Set immediate equalization mode activation on Program 35.

- When to Equalize

In float stage, when the setting equalization interval (battery equalization cycle) is arrived, or equalization is active immediately, the controller will start to enter Equalize stage.

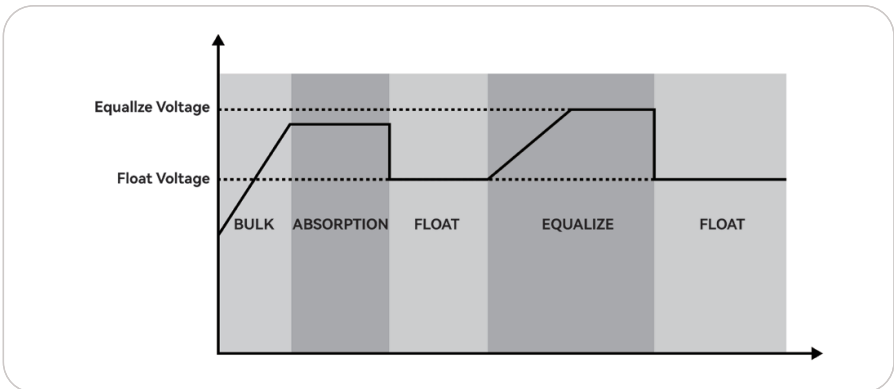

- Equalize charging time and timeout

In Equalize stage, the controller will supply power to charge battery as much as possible until battery voltage raises to battery equalization voltage. Then, constant-voltage regulation is applied to maintain battery voltage at the battery equalization voltage. The battery will remain in the Equalize stage until setting battery equalized time is arrived.

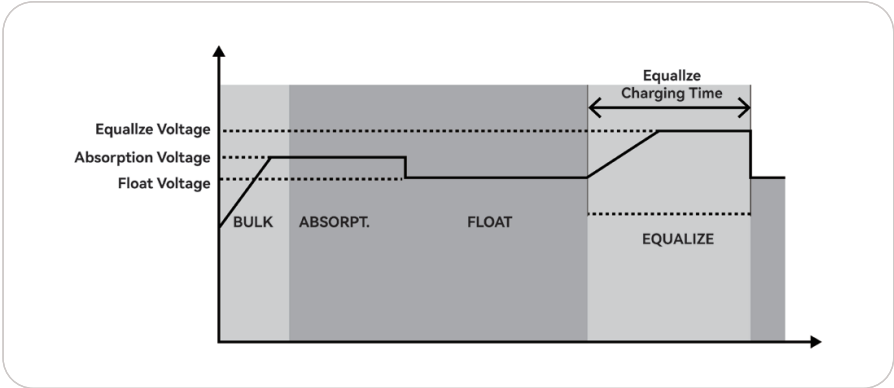

However, in Equalize stage, when battery equalized time is expired and battery voltage doesn't rise to battery equalization voltage point, the charge controller will extend the battery equalized time until battery voltage achieves battery equalization voltage. If battery voltage is still lower than battery equalization voltage when battery equalized timeout setting is over, the charge controller will stop equalization and return to float stage.

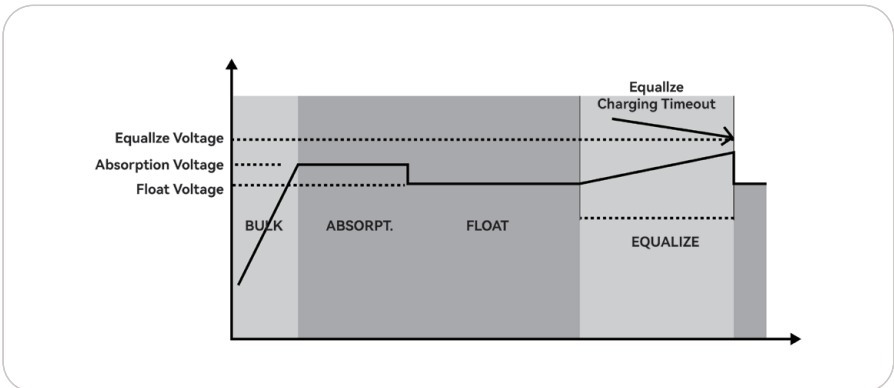

8. Trouble Shooting

Problem	Fault Event	Trigger conditions	What to do
LED screen display fault code 2	Bus voltage high	1. Check whether the total rated voltage of PV string exceeds the Max. PV open circuit voltage of inverter.	If it exceeds, reduce the PV module number.
		2. In case of parallel operation, check whether the output voltage settings of the two inverters are consistent.	If inconsistent, reset.
LED screen display fault code 3	Bus voltage low	1. Disconnect the load from inverter and restart again to observe if it recovers.	If it recovers, it indicates that there are too many impact loads and part of them should be removed from inverter.
LED screen display fault code 5	Over temperature	1. After the temperature is low, start the inverter output and check whether the fan rotates.	If the fan is not rotating, there may be a fault with the fan or its wiring.
		2. Check if the dust filter is too dirty.	If there is excessive dust accumulation, it needs to be cleaned.
		3. Check if there is a clearance space of more than 30cm around the machine.	If there is insufficient space, please refer to the user manual for reinstalling.
		4. Check if the ambient temperature is too high (above 45°C).	For example, avoid direct sunlight.
		5. Check if the air duct paper is loose.	Install the plastic nail provided by the manufacturer at the loose position
LED screen display fault code 26	BMS fault	1. Check the BMS fault information through the battery background controller.	Handle battery problems according to fault information.

LED screen display fault code 56	BMS loss	1. Check whether the communication cable is plugged into the correct port of the lithium battery.	The lithium battery may have multiple communication interfaces, which need to be plugged into the correct position.
		2. Check whether the battery dial switch setting is consistent with the protocol used.	The battery supports a variety of BMS protocols, and different protocols can be selected through the dial switch on the battery.
		3. Confirm whether the definition of battery port pin of BMS communication cable is consistent with that of inverter.	If not, replace the correct cable.
		4. Confirm whether the BMS protocol matches the inverter.	If it is not within the matching range of inverter, the Protocol shall be replaced.
		5. Replace the battery or inverter for test.	If it is normal after replacement, the communication hardware fails.
LED screen display fault code 58	Fan abnormal alarm	1. Confirm if the fan rotation is abnormal and if there is any foreign object causing obstruction.	Remove any foreign objects.
		2. Check if the fan is not connected or if the wiring is loose.	Ensure proper connection of the fan.
		3. Replace the fan to check if the fan is damaged.	Confirm damage and replace the fan.
LED screen display fault code 62	PV Energy Weak	1. Check if PV power is normal.	If abnormal, repair PV.
		2. Check if PV power is lower than load demand.	Remove part of the load.

Notes: Updates to the content and version of this manual will not be notified separately.





MPPT Solar Inverter

WJ-WHFCI-6500W-48V

Datasheet

1.Information

This datasheet is valid for the following machine:

- 6500W inverter

2.Introduction

2.1 Features

- Rated power 6.5kW/6.5kVA, power factor 1
- MPPT range 60V~450V, 500Voc
- High frequency with small size and light weight
- Pure sine wave AC output
- Solar and grid power loads at the same time
- CAN/RS485 for BMS communication
- Ability to work without battery
- WIFI remote monitoring (built-in)
- Dual AC output
- Feed-in to grid

2.2 Product Overview

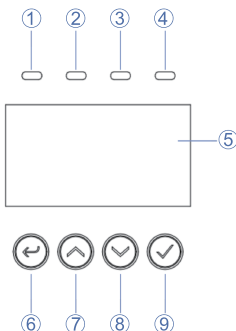
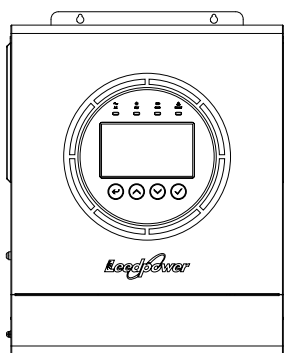

- ① AC Indicator
- ② Invert Indicator
- ③ Charging Indicator
- ④ Fault Indicator
- ⑤ LCD Display
- ⑥ ESC Button
- ⑦ Up Button
- ⑧ Down Button
- ⑨ Enter Button

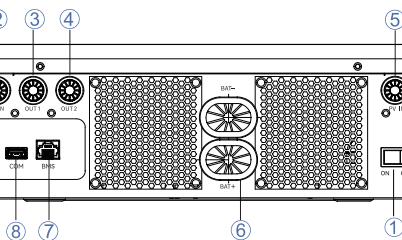
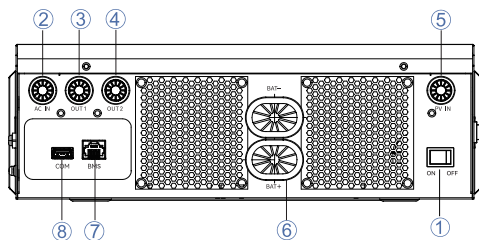

- ① Power On/Off Switch
- ② AC Input
- ③ AC Output 1
- ④ AC Output 2
- ⑤ PV Input
- ⑥ Battery Input
- ⑦ BMS Port
- ⑧ COM Port
- ⑨ AC Input Breaker
- ⑩ PE

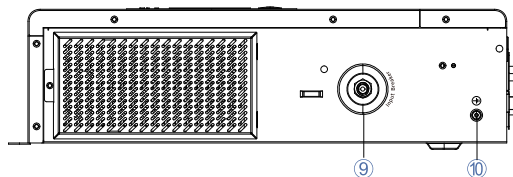

3. Packing List

No.	Item	Quantity	Description	Remarks
1	Inverter	1		
2	Datasheet	1	English	
3	User manual	1	English	
4	Tubular terminal	10	E6010	For AC input, AC output, PV input.
5	OT terminal	1		For PE

4.Specifications

AC Input	
Rated Input Voltage (VAC)	208/220/230/240; L+N+PE
Voltage Range (VAC)	90~280 (APP/GEN mode); 170~264 (UPS mode)
Frequency (Hz)	50/60 (Auto Adaptive)
AC Output	
Rated Capacity (kVA/kW)	6.5 (Output Power rating will be reduced to 90%, when setting the Output Voltage to 208V)
Surge Power (kVA)	12
Voltage (VAC)	208/220/230/240
Power Factor (PF)	1
Frequency (Hz)	50/60±0.1%
Switch Time (ms)	10 (APP/UPS mode) / 20 (GEN mode)
WaveForm	Pure SineWave
Overload Capacity (PV+Battery mode / PV mode)	1min@ 102%~120% load 10s@ 120%~200 load
Max. Efficiency (Battery Mode)	94%@48V
Charger(PV/AC)	
Solar Charger Type	MPPT
Max PV Input Current/Power	27A/9000W
MPPT Range@Operating Voltage (VDC)	60-450
PV Start-up Voltage (VDC)	80
Max PV Open Circuit Voltage (VDC)	500
Max PV Charge Current (A)	120
Max AC Charge Current (A)	120
Max. Charge Current (PV+AC) (A)	120
Battery	
Normal Voltage (VDC)	48
Battery Type	Lithium/Lead-acid
General Data	
HMI	LCD

Interface	RS485/CAN/RS232
Monitoring	WiFi (built-in)
Ingress Protection	IP21
Operating Temperature (°C)	-10~60
Relative Humidity	5%~95% (Non-condensing)
Storage Temperature (°C)	-15~60
Max. Operating Altitude (m)	4000 (Derating above 2000)

Maximum Load Capacity of Inverter

Only Battery	6000W@50V
Battery+PV	6500W
Bypass Current	40A @25°C

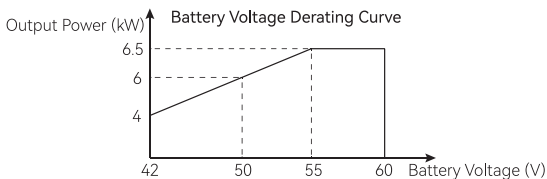

5. Notes about Installation

1. The L and N cable of the AC Input port must not be reverse-connected. The tool used to distinguish between L and N cable is voltage tester (test pen) or multimeter.

Notes: Updates to the content and version of this datasheet will not be notified separately.



WJ-WHFCI-6500W-48V

