



ENERGY
SAVING



EASY TO
INSTALL



HIGH
QUALITY

Contact Us

GUANGZHOU LEED POWER CO., LTD

+0086-13717793357

sales@leedpower.com

Room 408, Building 1, Tianan Technology Industry Building, Panyu Energy-Saving Technology Park, 555 North Panyu Avenue, Donghuan Street, Panyu District, Guangzhou City, China



WhatsApp



Line

Scan the code to contact us

PRODUCT SELECTION GUIDE

GUANGZHOU LEED POWER CO., LTD

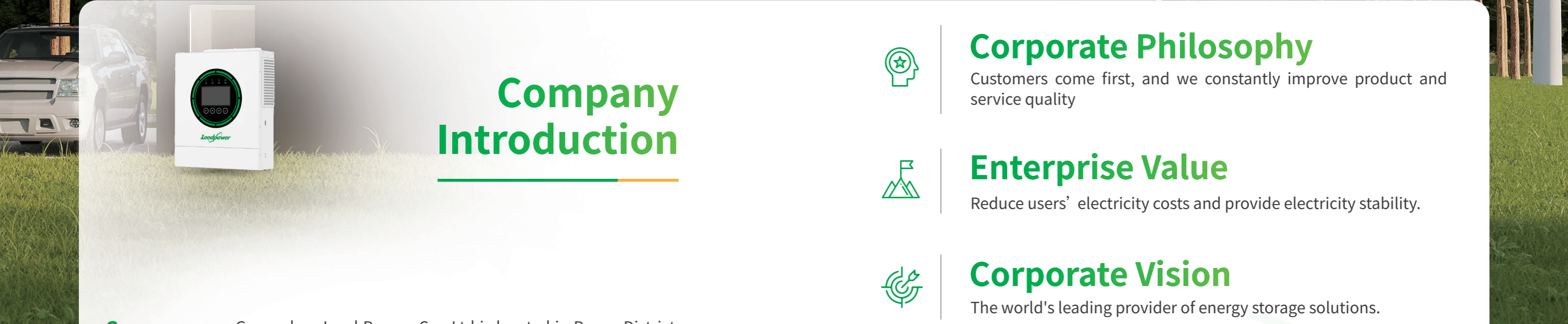

Company Introduction

Company Overview

Guangzhou Leed Power Co., Ltd is located in Panyu District, Guangzhou, China. It is committed to providing energy storage solutions to household users around the world. It is a high-tech enterprise integrating the design and installation of household photovoltaic energy storage systems. It is a high-quality product in the new energy field. Our company is the truly advocates and promoters of new energy.

Main Products

The company's main products include solar modules, Solar Energy Storage Inverter, Solar Inverter, lithium iron phosphate batteries, etc.

Business Scope

Leed Power provides household energy storage solutions and after-sales services to users in more than 100 countries and regions around the world.



Corporate Philosophy

Customers come first, and we constantly improve product and service quality



Enterprise Value

Reduce users' electricity costs and provide electricity stability.



Corporate Vision

The world's leading provider of energy storage solutions.

Business Segment

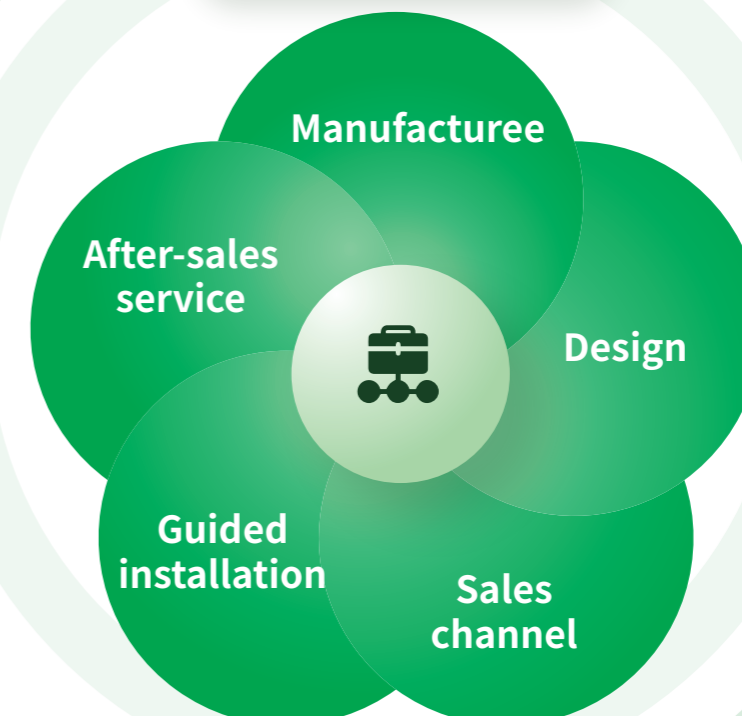

Features Of Home Green Electricity

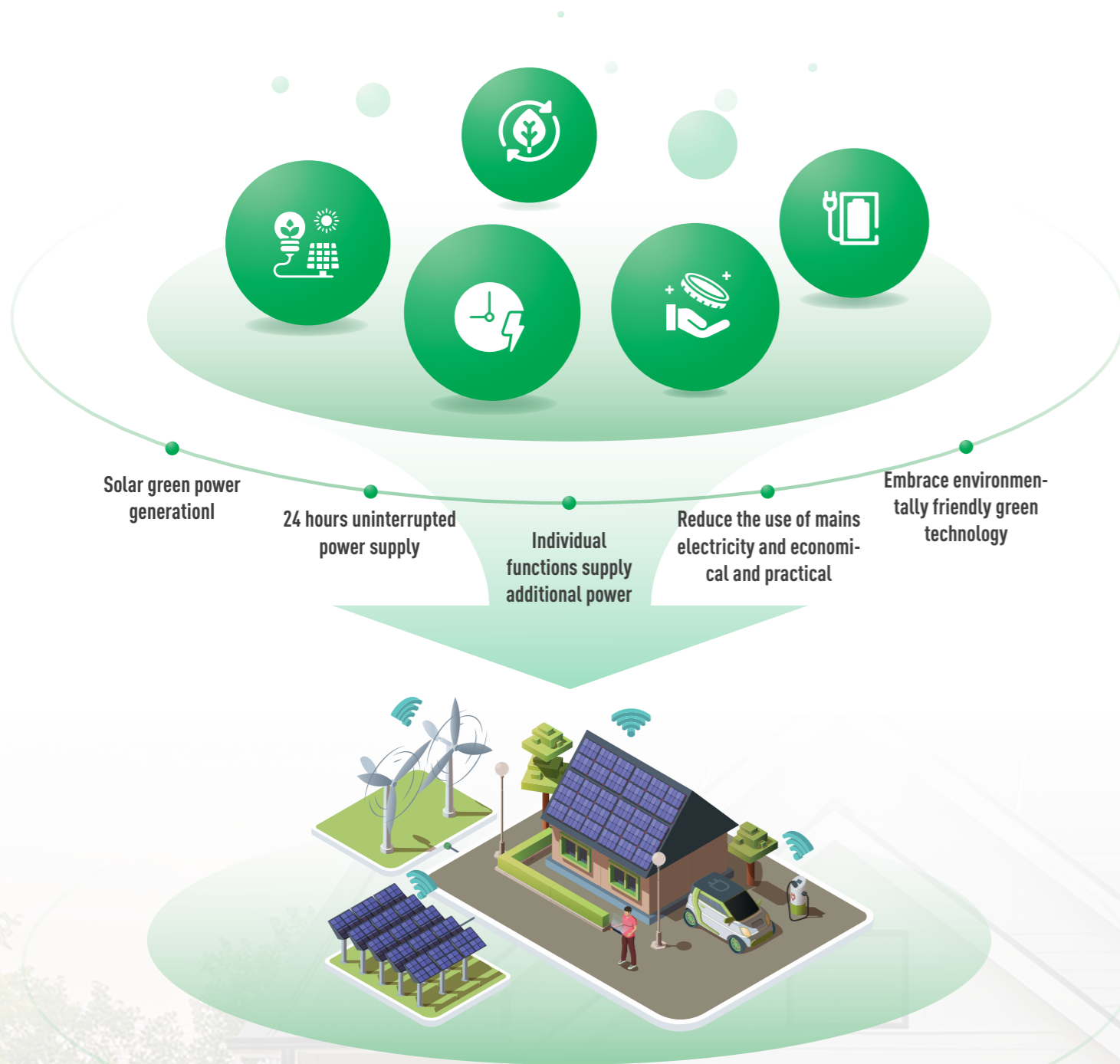

Solar Inverter Solutions

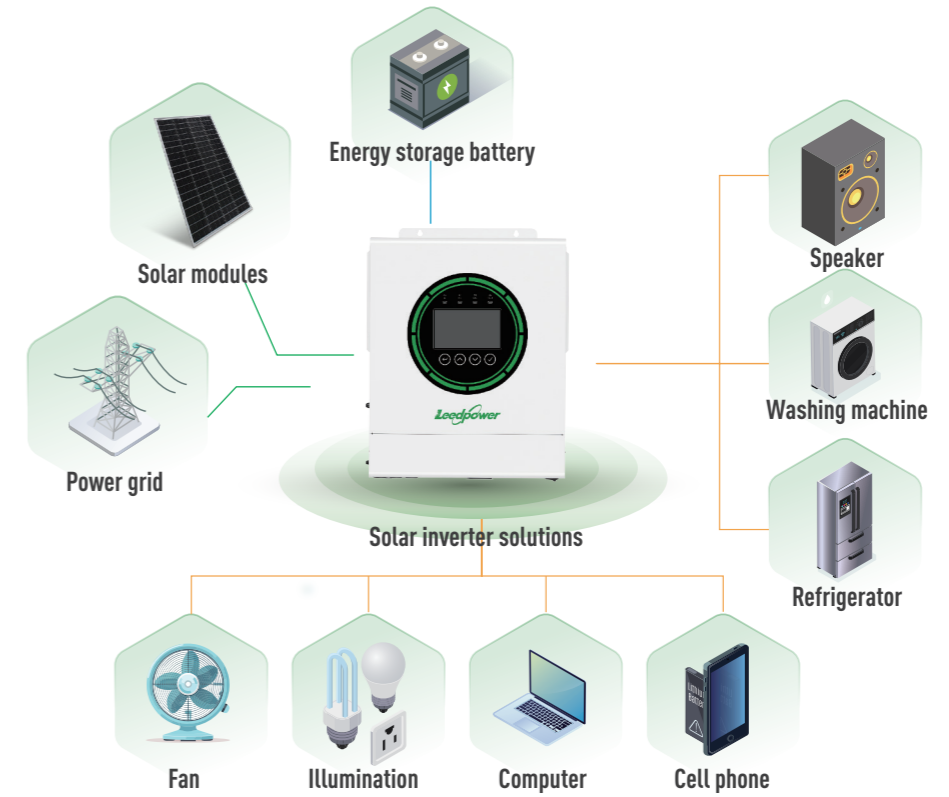

Solar Inverter System Diagram

Green Electricity Generation Process

01 Solar panels are used to convert sunlight into electrical energy to provide electricity for the home during the day.

02 Equipped with an energy storage battery system to store excess electricity generated during the day for use at night or when there is insufficient light.

System Composition



Solar Photovoltaic Panel

The basic component that converts sunlight into DC electricity.



Energy Storage Battery

stores the energy generated by photovoltaic panels for use at night or when there is no light.



Solar Energy Storage Inverter

- 01. Solar controller module regulates and manages the electric energy generated by solar panels, protects the battery from the effect of excessive current and overcharge damage, and extends the service life of the battery.
- 02. Inverter module: Converts DC power into AC power that can be used in homes.

Program Features



Efficient Power Generation

Use photovoltaic panels with high conversion efficiency to maximize the utilization of solar energy.



Modular Design

System components can be flexibly configured according to the specific needs of the home



Safety Protection

It has complete overload, short circuit, leakage and other protection functions to ensure safety use



Environmental Adaptability

The system design takes into account different climate and environmental factors to ensure stable operation



3600W Solar Inverter Package

Number	Product Name	Quantity	Unit
3600w Solar Inverter 5kwh battery 1600w battery panel			
1	200W Solar panels	8	Piece
2	3600W Solar Inverter	1	Unit
3	5kwh	1	Piece
4	Solar panel bracket	8	Set
5	Photovoltaic input box	1	Unit
6	Photovoltaic supporting connection line	1	Set



Daily power generation is about 2.4kwh~8.0kwh Power storage capacity: 5.0kwh

Loading conditions:

a 20W light bulb + a 500W washing machine + a 500W mini rice cooker + a 200W refrigerator + a 50W TV + a 50W fan + a mobile phone charger, can run continuously for 2.5 hours.

6500W Solar Inverter Package

Number	Product Name	Quantity	Unit
6500w Solar Inverter 10kwh battery 3600w battery panel			
1	580W Solar panels	6	Piece
2	6500W Solar Inverter	1	Unit
3	10kwh	1	Piece
4	Solar panel bracket	1	Set
5	Photovoltaic input box	1	Unit
6	Photovoltaic supporting connection line	1	Set



Daily power generation is about 5.4kwh~18kwh Power storage capacity: 10kwh

Loading conditions:

a 20W light bulb + a 500W washing machine + a 500W rice cooker + a 200W refrigerator + a 50W TV + a 50W fan + an 800W air conditioner + a mobile phone charger can run continuously for 3.0 hours.

12000W Solar Inverter Package

Number	Product Name	Quantity	Unit
12000w Solar Inverter 20kwh battery 8120w battery panel			
1	580W Solar panels	14	Piece
2	12000W Solar Inverter	1	Unit
3	10kwh	2	Piece
4	Solar panel bracket	1	Set
5	Photovoltaic input box	1	Unit
6	Photovoltaic supporting connection line	1	Set



Daily power generation is about 12kwh~40.6kwh Power storage capacity: 10kwh

Loading conditions:

5x20W light bulb + a 1000W washing machine + a 500W rice cooker + a 300W refrigerator + a 50W TV + a 50W fan + 3* 800W air conditioner + 1* 2000W heater + a mobile phone charger can run continuously for 4.5 hours.



Wall-mounted solar hybrid inverter — LD-WHFCI-3600W-24V



Product overview

The WHFCI series high-frequency hybrid solar inverters adopt a high-frequency bidirectional energy storage architecture design, enabling bidirectional charging and discharging management of the battery by both photovoltaic (PV) and mains power. When PV power generation generates surplus electricity, the system prioritizes charging the battery; when PV power generation is insufficient, it can automatically switch to mains power or battery power to supply the load, thereby improving the efficiency of PV energy utilization and ensuring the continuity and stability of power supply.

Product features

- 01 Built-in 100A Solar Charger
- 02 Wide PV Input Voltage Range 40-500V
- 03 Feed-in to Grid
- 04 Dual AC Output
- 05 Support Lithium/Lead-acid Battery
- 06 Lithium Battery Activation
- 07 Detachable Dust Cover
- 08 WiFi Monitoring(optional)

System Diagram

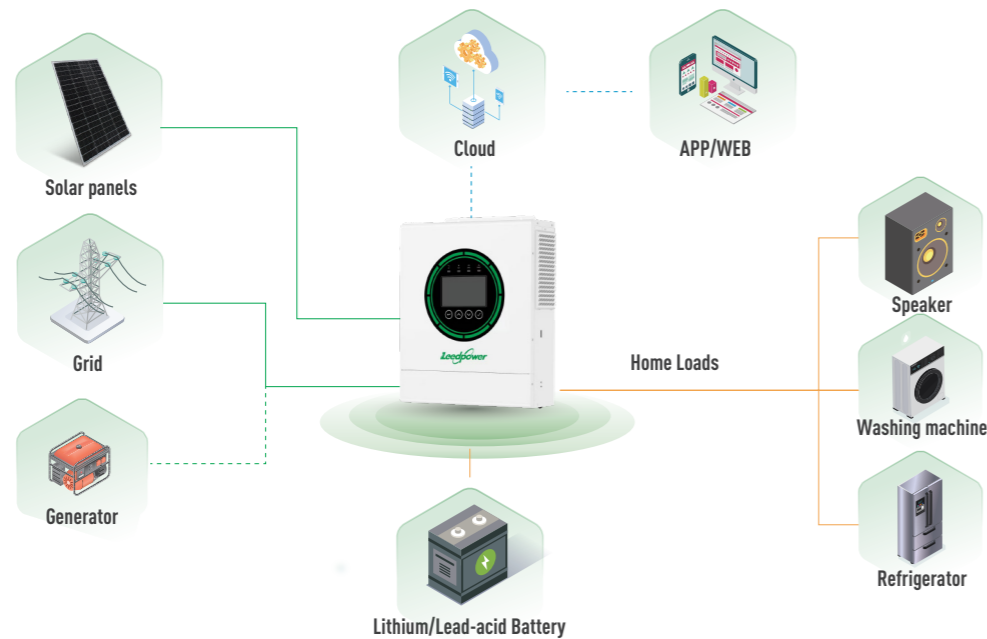

Product Specifications

Model	LD-WHFCI-3600W-24V
AC Input	
Rated Input Voltage (VAC)	208/220/230/240;L + N + PE
Voltage Range (VAC)	90~280 (APP/GEN mode); 170~264 (UPS mode)
Frequency (Hz)	50/ 60 (Auto Adaptive)
AC Output	
Rated Capacity (kVA/kW)	3.6
Surge Power (kVA)	7.2
Voltage (VAC)	208/220/230/240
Power Factor (PF)	1
Frequency (Hz)	50/60
Switch Time (ms)	10 (APP/UPS mode)/20 (GEN mode)
Wave Form	Pure Sine Wave
Overload Capacity (Battery Mode)	1min@102%-110% load, 10s@110%-200% load
Max. Efficiency (Battery Mode)	92.7%@24VDC
Parallel Quantity	NA
Charger (PV /AC)	
Solar Charger Type	MPPT
Max. PV input Current (A) / Input Power(W)	18/5000
MPPT Range@Operating Voltage (VDC)	40~450
Max. PV Open Circuit Voltage (VDC)	500
Max. PV Charge Current (A)	100
Max. AC Charge Current (A)	100
Max. Charge Current (PV + AC) (A)	100
Battery	
Rated Voltage (VDC)	24
Max. Charging Current (A)	100
Max. Discharging Current (A)	150
Battery Type	Lithium / Lead-acid
Interface	
HMI	LCD
Interface	RS485 / CAN / RS232
Monitoring	WiFi (optional/built-in/external)
General Data	
Ingress Protection	IP21
Operating Temperature (°C)	-10~60
Relative Humidity	5% ~ 95% (Non-condensing)
Storage Temperature (°C)	-15~60
Net Weight (kg)	6.2
Gross Weight (kg)	7.3
Product Dimensions (H*W*D) (mm)	420*284*94 (without bracket)
Package Dimensions(H*W*D) (mm)	518×342×170mm
Max. Operating Altitude (m)	4000 (Derating above 2000)

Wall-mounted solar hybrid inverter — LD-WHFCI-6500W-48V



Product overview

The WHFCI series high-frequency hybrid solar inverters adopt a high-frequency bidirectional energy storage architecture design, enabling bidirectional charging and discharging management of the battery by both photovoltaic (PV) and mains power. When PV power generation generates surplus electricity, the system prioritizes charging the battery; when PV power generation is insufficient, it can automatically switch to mains power or battery power to supply the load, thereby improving the efficiency of PV energy utilization and ensuring the continuity and stability of power supply.

Product features

- 01 Built-in 120A Solar Charger
- 02 Wide PV Input Voltage Range 60-500V
- 03 27A MAX PV Input
- 04 Dual AC Out
- 05 Support Lithium/Lead-acid Battery
- 06 Lithium Battery Activation
- 07 Feed-in to Grid
- 08 WiFi Monitoring(optional)
- 09 5 Inch Display

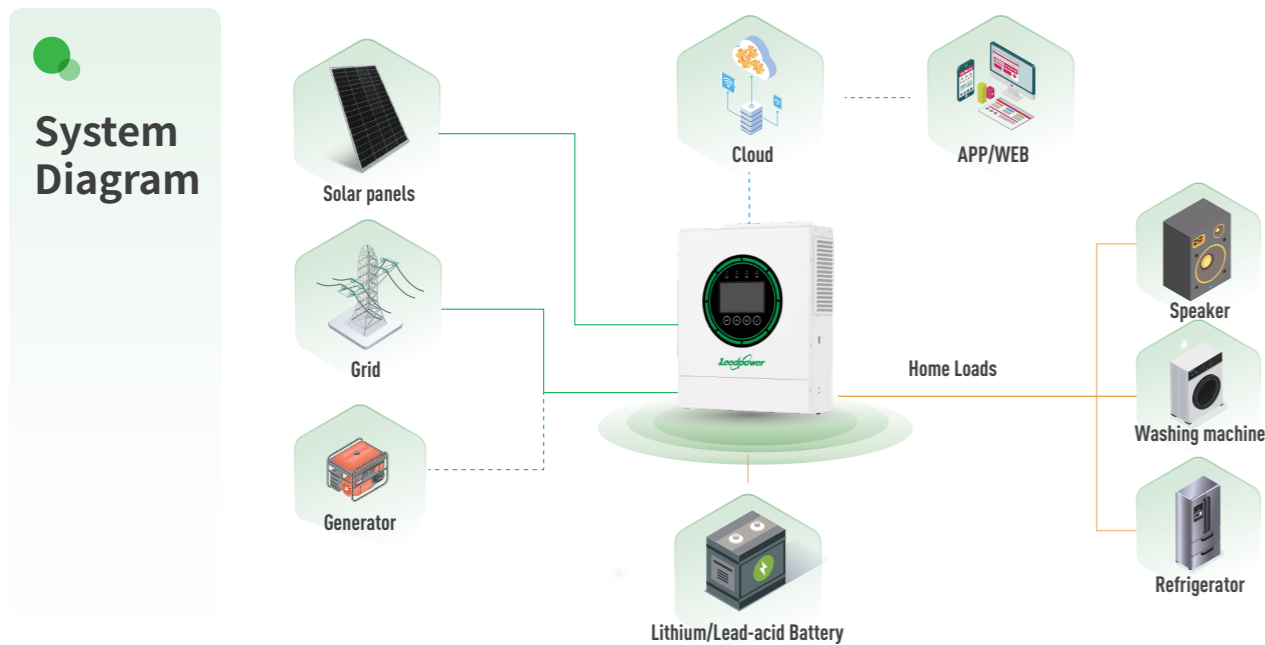

Product Specifications

Model	LD-WHFCI-6500W-48V
AC Input	
Rated Input Voltage (VAC)	208/220/230/240;L + N + PE
Voltage Range (VAC)	90~280 (APP/GEN mode); 170~264 (UPS mode)
Frequency (Hz)	50/ 60 (Auto Adaptive)
AC Output	
Rated Capacity (kVA/kW)	6.5
Surge Power (kVA)	12
Voltage (VAC)	208/220/230/240
Power Factor (PF)	1
Frequency (Hz)	50/60
Switch Time (ms)	10 (APP/UPS mode)/20 (GEN mode)
Wave Form	Pure Sine Wave
Overload Capacity (Battery Mode)	1min@102%-110% load, 10s@110%-200% load
Max. Efficiency (Battery Mode)	94%@48VDC
Parallel Quantity	NA
Charger (PV /AC)	
Solar Charger Type	MPPT
Max. PV input Current (A) / Input Power(W)	27/9000
MPPT Range@Operating Voltage (VDC)	60~450
Max. PV Open Circuit Voltage (VDC)	500
Max. PV Charge Current (A)	120
Max. AC Charge Current (A)	120
Max. Charge Current (PV + AC) (A)	120
Battery	
Rated Voltage (VDC)	48
Max. Charging Current (A)	120
Max. Discharging Current (A)	140
Battery Type	Lithium / Lead-acid
Interface	
HMI	5 inch LCD
Interface	RS485 / CAN / RS232
Monitoring	WiFi (optional/built-in/external)
General Data	
Ingress Protection	IP21
Operating Temperature (°C)	-10~60
Relative Humidity	5% ~ 95% (Non-condensing)
Storage Temperature (°C)	-15~60
Net Weight (kg)	8.4
Gross Weight (kg)	9.5
Dimensions (H*W*D) (mm)	410*336*110 (without bracket)
Package Dimensions(H*W*D) (mm)	490×394×176mm
Max. Operating Altitude (m)	4000 (Derating above 2000)

Wall-mounted solar hybrid inverter — LD-WHFCI-6500W-48V-EN



Product overview

The WHFCI series high-frequency hybrid solar inverters adopt a high-frequency bidirectional energy storage architecture design, enabling bidirectional charging and discharging management of the battery by both photovoltaic (PV) and mains power. When PV power generation generates surplus electricity, the system prioritizes charging the battery; when PV power generation is insufficient, it can automatically switch to mains power or battery power to supply the load, thereby improving the efficiency of PV energy utilization and ensuring the continuity and stability of power supply.

Product features

- 01 Built-in 120A Solar Charger
- 02 Wide PV Input Voltage Range 60-500V
- 03 27A MAX PV Input
- 04 Dual AC Out
- 05 Support Lithium/Lead-acid Battery
- 06 Lithium Battery Activation
- 07 Feed-in to Grid
- 08 WiFi Monitoring(optional)
- 09 5 Inch Display

System Diagram

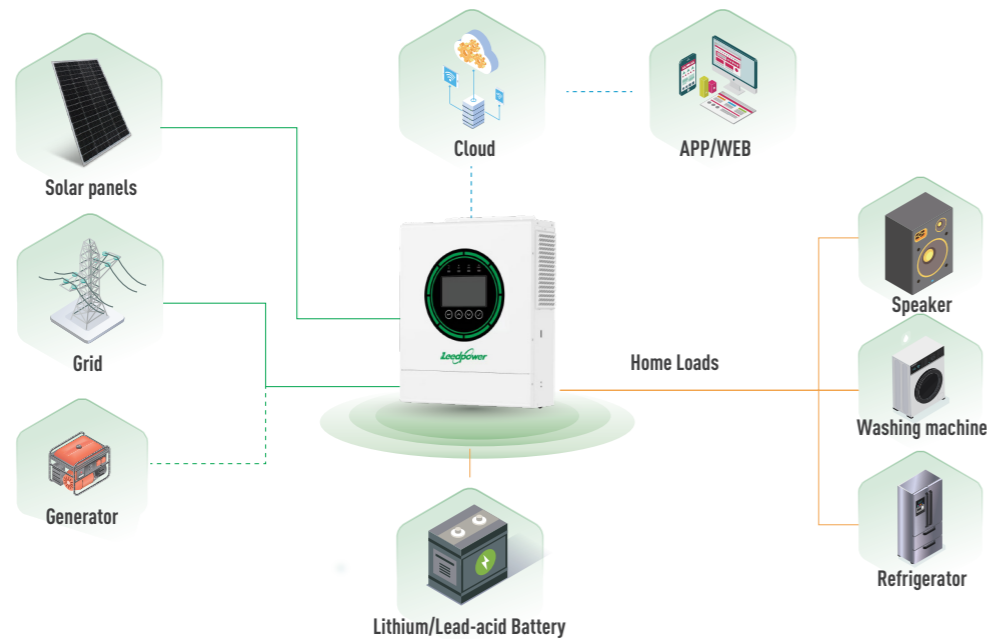

Product Specifications

Model	LD-WHFCI-6500W-48V-EN
AC Input	
Rated Input Voltage (VAC)	208/220/230/240;L + N + PE
Voltage Range (VAC)	90~280 (APP/GEN mode); 170~264 (UPS mode)
Frequency (Hz)	50/ 60 (Auto Adaptive)
AC Output	
Rated Capacity (kVA/kW)	6.5
Surge Power (kVA)	12
Voltage (VAC)	208/220/230/240
Power Factor (PF)	1
Frequency (Hz)	50/60
Switch Time (ms)	10 (APP/UPS mode)/20 (GEN mode)
Wave Form	Pure Sine Wave
Overload Capacity (Battery Mode)	1min@102%-110% load, 10s@110%-200% load
Max. Efficiency (Battery Mode)	94%@48VDC
Parallel Quantity	NA
Charger (PV /AC)	
Solar Charger Type	MPPT
Max. PV input Current (A) / Input Power(W)	27/9000
MPPT Range@Operating Voltage (VDC)	60~450
Max. PV Open Circuit Voltage (VDC)	500
Max. PV Charge Current (A)	120
Max. AC Charge Current (A)	120
Max. Charge Current (PV + AC) (A)	120
Battery	
Rated Voltage (VDC)	48
Max. Charging Current (A)	120
Max. Discharging Current (A)	140
Battery Type	Lithium / Lead-acid
Interface	
HMI	5 inch LCD
Interface	RS485 / CAN / RS232
Monitoring	WiFi (optional/built-in/external)
General Data	
Ingress Protection	IP54
Operating Temperature (°C)	-10~60
Relative Humidity	5% ~ 95% (Non-condensing)
Storage Temperature (°C)	-15~60
Net Weight (kg)	8.4
Gross Weight (kg)	9.5
Dimensions (H*W*D) (mm)	410*336*110 (without bracket)
Package Dimensions(H*W*D) (mm)	490×394×176mm
Max. Operating Altitude (m)	4000 (Derating above 2000)

Wall-mounted solar hybrid inverter — LD-WHFCI-12000W-48V



Product overview

The WHFCI series high-frequency hybrid solar inverters adopt a high-frequency bidirectional energy storage architecture design, enabling bidirectional charging and discharging management of the battery by both photovoltaic (PV) and mains power. When PV power generation generates surplus electricity, the system prioritizes charging the battery; when PV power generation is insufficient, it can automatically switch to mains power or battery power to supply the load, thereby improving the efficiency of PV energy utilization and ensuring the continuity and stability of power supply.

Product features

- 01 Built-in 160A Solar Charger
- 02 Wide PV Input Voltage Range 60-500V
- 03 Dual MPPTs Input
- 04 27A+27A MAX PV Input
- 05 Support Lithium/Lead-acid Battery
- 06 Lithium Battery Activation
- 07 Feed-in to Grid
- 08 WiFi Monitoring(optional)
- 09 5 Inch Display
- 10 Dual AC Out

System Diagram

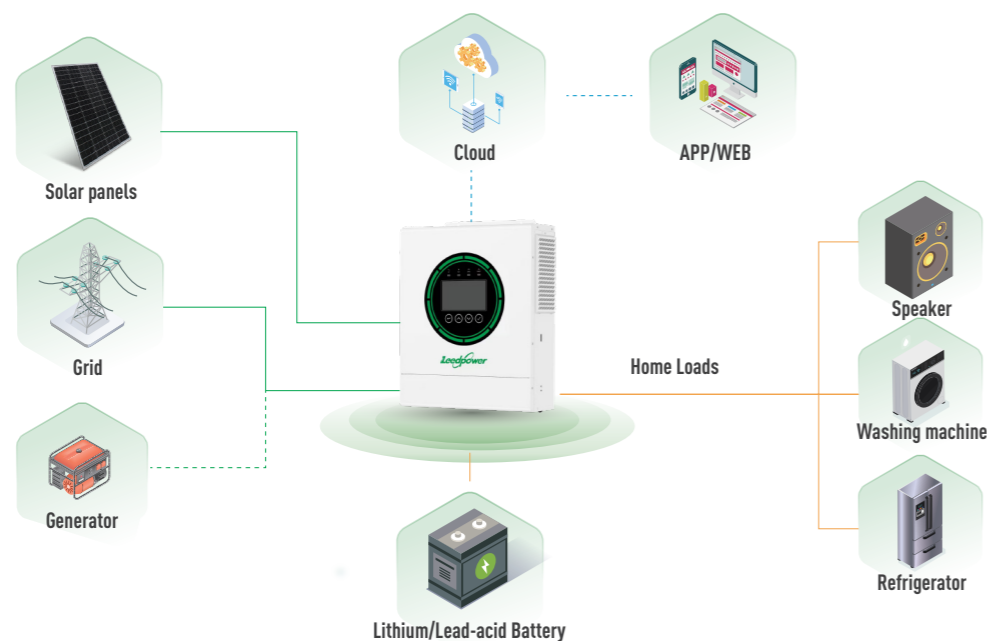

Product Specifications

Model	LD-WHFCI-12000W-48V
AC Input	
Rated Input Voltage (VAC)	220/230/240;L + N + PE
Voltage Range (VAC)	90~280 (APP/GEN mode); 170~264 (UPS mode)
Frequency (Hz)	50/ 60 (Auto Adaptive)
AC Output	
Rated Capacity (kVA/kW)	12
Surge Power (kVA)	24
Voltage (VAC)	220/230/240
Power Factor (PF)	1
Frequency (Hz)	50/60
Switch Time (ms)	10 (APP/UPS mode)/20 (GEN mode)
Wave Form	Pure Sine Wave
Overload Capacity(PV+Battery mode /PV Mode)	1min@102%-125% Load, 10s@125%-200% Load
Max. Efficiency (Battery Mode)	94%@48VDC
Parallel Quantity	NA
Charger (PV /AC)	
Solar Charger Type	Dual MPPTs
Max. PV input Current (A) / Input Power(W)	Using One MPPT: 27A/9KW Using Two MPPTs: 27A/Per MPPT, 15kW/Total
MPPT Range@Operating Voltage (VDC)	60~450
Max. PV Open Circuit Voltage (VDC)	500
Max. PV Charge Current (A)	160
Max. AC Charge Current (A)	160
Max. Charge Current (PV + AC) (A)	160
Battery	
Rated Voltage (VDC)	48
Max. Charging Current (A)	160
Max. Discharging Current (A)	220
Battery Type	Lithium / Lead-acid
Interface	
HMI	5 inch LCD
Interface	RS485 / CAN / RS232
Monitoring	WiFi (optional/built-in/external)
General Data	
Ingress Protection	IP21
Operating Temperature (°C)	-10~60
Relative Humidity	5% ~ 95% (Non-condensing)
Storage Temperature (°C)	-15~60
Net Weight (kg)	15
Gross Weight (kg)	16.5
Dimensions (H*W*D) (mm)	495*425*120 (without bracket)
Package Dimensions(H*W*D) (mm)	594×500×210mm
Max. Operating Altitude (m)	4000 (Derating above 2000)

Wall-mounted solar hybrid inverter — LD-WHFCI-3KW-24V-IP65



System Diagram

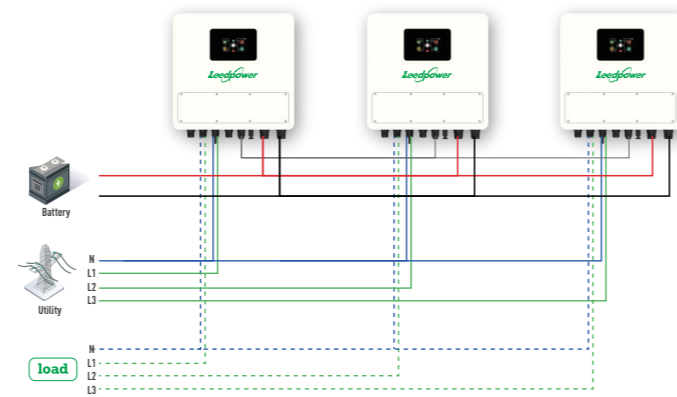

Product features

Parallel Operation Up to 6 Units

High Efficiency Max.98%

Current Transformer

50-500Vdc(6KW)

Maximize PV Input Power(2 MPPTs)

Touchscreen

2 Independent AC Inputs
2 Outputs

Wi-Fi

Product Specifications

Model	LD-WHFCI-3KW-24V-IP65
PHASE	1-phase in /1-phase out
MAXIMUM PV INPUT POWER	4500W
RATED OUTPUT POWER	3000W
MAXIMUM CHARGING POWER	3000W
OFF-GRID OPERATION	
AC INPUT	
AC Start-up Voltage	170VAC-280 VAC
Acceptable Input Voltage Range	90-280 VAC(APL)or170-280VAC(UPS)
Frequency Range	50 Hz/60 Hz(Auto sensing)
Maximum AC Input Current	16A
PV INPUT(DC)	
Maximum DC Voltage	500Vdc
MPPT Voltage Range	60Vdc-450Vdc
Number of MPPT Trackers/Maximum Input Current	1/18A
BATTERY MODE OUTPUT(AC)	
Nominal Output Voltage	220/230/240VAC
Output Waveform	Pure sine wave
Efficiency (DC to AC)	93%
HYBRID OPERATION	
PV INPUT(DC)	
Maximum DC Voltage	500Vdc
Start-up Voltage/Initial Feeding Voltage	90Vdc/120Vdc
MPPT Voltage Range	60Vdc-450Vdc
Number of MPPT Trackers/Maximum Input Current	1/18A
GRID OUTPUT(AC)	
Nominal Output Voltage	220/230/240VAC
Output Voltage Range	184-264.5 VAC or 195.5-253 VAC or 184-264.4 VAC(Selectable)
Nominal Output Current	13A
AC INPUT	
AC Start-up Voltage	170VAC-280 VAC
Acceptable Input Voltage Range	90-280VAC or 170-280 VAC
Maximum AC Input Current	16A
BATTERY MODE OUTPUT(AC)	
Nominal Output Voltage	220/230/240VAC
Efficiency (DC to AC)	93%
BATTERY & CHARGER	
Nominal DC Voltage	24Vdc
Maximum Solar Charging Current	100A
Maximum AC Charging Current	100A
Maximum Charging Current	100A
GENERAL	
PHYSICAL	
Dimension, D x W x H(mm)	451x353x160.2
Net Weight (kg)	12.3
INTERFACE	
Communication Port	RS232/RS485/Wi-Fi
ENVIRONMENT	
Humidity	5% to 95% Relative Humidity(Non-condensing)
IP degree	IP65
Operating Temperature	-10°C~50°C
Storage Temperature	-15°C~60°C

Wall-mounted solar hybrid inverter— LD-WHFCI-6KW-48V-IP65



System Diagram

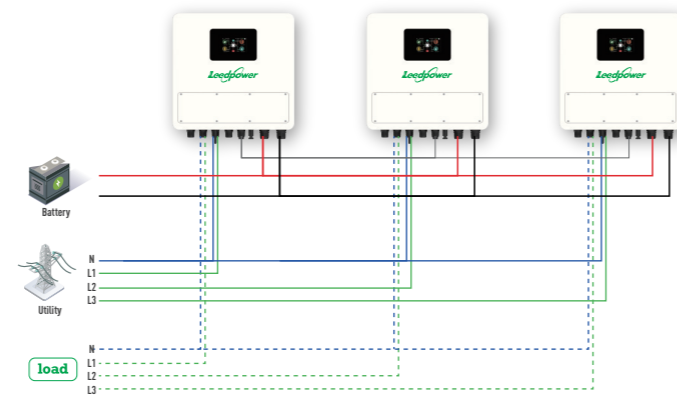

Product features

Parallel Operation Up to 6 Units

High Efficiency Max.98%

Current Transformer

50-500Vdc(6KW)

Maximize PV Input Power(2 MPPTs)

Touchscreen

2 Independent AC Inputs
2 Outputs

Wi-Fi

Product Specifications

Model	LD-WHFCI-6KW-48V-IP65
PHASE	1-phase in /1-phase out
MAXIMUM PV INPUT POWER	4500W+4500W
RATED OUTPUT POWER	6000W
MAXIMUM CHARGING POWER	6000W
GRID-TIED OPERATION	
PV INPUT(DC)	
Maximum DC Voltage	520Vdc
Start-up Voltage /Initial Feeding Voltage	90Vdc/120Vdc
MPPT Voltage Range	50Vdc-500Vdc
Number of MPPT Trackers /Maximum Input Current	2/18A
GRID OUTPUT(AC)	
Nominal Output Voltage	220/230/240VAC
Output Voltage Range	184-264.5 VAC or 195.5-253 VAC or 184-264.4 VAC(Selectable)
Nominal Output Current	26.1A
Power Factor	>0.99
EFFICIENCY	
Maximum Conversion Efficiency(DC/AC)	97%
OFF-GRID OPERATION	
AC INPUT	
AC Start-up Voltage	170VAC-280 VAC
Acceptable Input Voltage Range	90-280 VAC(APL)or170-280VAC(UPS)
Frequency Range	50 Hz/60 Hz(Auto sensing)
Maximum AC Input Current	35A
PV INPUT(DC)	
Maximum DC Voltage	520Vdc
MPPT Voltage Range	50Vdc-500Vdc
Number of MPPT Trackers/Maximum Input Current	2/18A
BATTERY MODE OUTPUT(AC)	
Nominal Output Voltage	220/230/240VAC
Output Waveform	Pure sine wave
Efficiency (DC to AC)	93%
HYBRID OPERATION	
PV INPUT(DC)	
Maximum DC Voltage	520Vdc
Start-up Voltage/Initial Feeding Voltage	90Vdc/120Vdc
MPPT Voltage Range	50Vdc-500Vdc
Number of MPPT Trackers/Maximum Input Current	2/18A
GRID OUTPUT(AC)	
Nominal Output Voltage	220/230/240VAC
Output Voltage Range	184-264.5 VAC or 195.5-253 VAC or 184-264.4 VAC(Selectable)
Nominal Output Current	26.1A
AC INPUT	
AC Start-up Voltage	170VAC-280 VAC
Acceptable Input Voltage Range	90-280VAC or 170-280 VAC
Maximum AC Input Current	35A
BATTERY MODE OUTPUT(AC)	
Nominal Output Voltage	220/230/240VAC
Efficiency (DC to AC)	93%
BATTERY & CHARGER	
Nominal DC Voltage	48Vdc
Maximum Solar Charging Current	125A
Maximum AC Charging Current	125A
Maximum Charging Current	125A
GENERAL	
PHYSICAL	
Dimension, D x W x H(mm)	493x499x200
Net Weight (kg)	18.7
INTERFACE	
Parallel Function	Yes, 6 units
Communication Port	RS485/CAN/Wi-Fi/Dry contact
ENVIRONMENT	
Humidity	5% to 95% Relative Humidity(Non-condensing)
IP degree	IP65
Operating Temperature	-10°C~50°C
Storage Temperature	-15°C~60°C

High Frequency Solar Energy Storage Inverter — LD-LHFES-3.6KW-5kwh



Product overview

The LHFES series integrates the functions of a solar charge controller, an inverter, and a battery, offering capabilities for solar charging, power inversion, and energy storage. Its intuitive LCD interface allows users to easily monitor the device's operational status. The unit features user-friendly controls, including AC output sockets for lighting, a DC battery circuit breaker, and an AC output switch.

Product features

- 01** Built-in solar charger, energy storage batter
- 02** Simple installation and connection method saves installation time and steps
- 03** LCD display for easy viewing of equipment operating data
- 04** Portable design, all in one machine

Product Specifications

Model	LD-LHFES-3.6KW-5kwh
AC Input	
Rated Input Voltage (VAC)	208/220/230/240;L + N + PE
Voltage Range (VAC)	90~280 (APP/GEN mode); 170~264 (UPS mode)
Frequency (Hz)	50/ 60 (Auto Adaptive)
AC Output	
Rated Capacity (kVA/kW)	3.6
Surge Power (kVA)	7.2
Voltage (VAC)	208/220/230/240
Power Factor (PF)	1
Frequency (Hz)	50/60
Switch Time (ms)	10 (APP/UPS mode)/20 (GEN mode)
Wave Form	Pure Sine Wave
Overload Capacity (Battery Mode)	1min@102%-110% load, 10s@110%-200% load
Max. Efficiency (Battery Mode)	92.7%@24VDC
Parallel Quantity	NA
battery pack	
Battery rated input voltage	25.6VDC
Float charge voltage	27V
Battery Type	Lithium iron phosphate battery
Built-in battery specifications	25.6V 225Ah (lithium iron phosphate battery)
Charger (PV /AC)	
Solar Charger Type	MPPT
Max. PV input Current (A) / Input Power(W)	18/5000
MPPT Range@Operating Voltage (VDC)	40~450
Max. PV Open Circuit Voltage (VDC)	500
Max. PV Charge Current (A)	100
Max. AC Charge Current (A)	100
Max. Charge Current (PV + AC) (A)	100
Interface	
HMI	LCD
Interface	RS485 / CAN / RS232
Monitoring	WiFi (optional/built-in/external)
General Data	
Ingress Protection	IP21
Operating Temperature (°C)	-10~60
Relative Humidity	5% ~ 95% (Non-condensing)
Storage Temperature (°C)	-15~60
Net Weight (kg)	55kg
Gross Weight (kg)	60kg
Dimensions (H*W*D) (mm)	610×419×323mm
Packaging Dimensions (H*W*D) (mm)	650×480×383mm

High Frequency Solar Energy Storage Inverter — LD-LHFES-6.5KW-10kwh



Product overview

The LHFES series integrates the functions of a solar charge controller, an inverter, and a battery, offering capabilities for solar charging, power inversion, and energy storage. Its intuitive LCD interface allows users to easily monitor the device's operational status. The unit features user-friendly controls, including AC output sockets for lighting, a DC battery circuit breaker, and an AC output switch.

Product features

- 01** Built-in solar charger, energy storage battery
- 02** Simple installation and connection method saves installation time and steps
- 03** LCD display for easy viewing of equipment operating data
- 04** Portable design, all in one machine

Product Specifications

Model	LD-LHFES-6.5KW-10kwh
AC Input	
Rated Input Voltage (VAC)	208/220/230/240;L + N + PE
Voltage Range (VAC)	90~280 (APP/GEN mode); 170~264 (UPS mode)
Frequency (Hz)	50/ 60 (Auto Adaptive)
AC Output	
Rated Capacity (kVA/kW)	6.5
Surge Power (kVA)	12
Voltage (VAC)	208/220/230/240
Power Factor (PF)	1
Frequency (Hz)	50/60
Switch Time (ms)	10 (APP/UPS mode)/20 (GEN mode)
Wave Form	Pure Sine Wave
Overload Capacity (Battery Mode)	1min@102%-110% load, 10s@110%-200% load
Max. Efficiency (Battery Mode)	94%@48VDC
Parallel Quantity	NA
battery pack	
Battery rated input voltage	48VDC
Float charge voltage	50.6V
Battery Type	Lithium iron phosphate battery
Built-in battery specifications	48V 225Ah (lithium iron phosphate battery)
Charger (PV /AC)	
Solar Charger Type	MPPT
Max. PV input Current (A) / Input Power(W)	27/9000
MPPT Range@Operating Voltage (VDC)	60~450
Max. PV Open Circuit Voltage (VDC)	500
Max. PV Charge Current (A)	120
Max. AC Charge Current (A)	120
Max. Charge Current (PV + AC) (A)	120
Interface	
HMI	5 inch LCD
Interface	RS485 / CAN / RS232
Monitoring	WiFi (optional/built-in/external)
General Data	
Ingress Protection	IP21
Operating Temperature (°C)	-10~60
Relative Humidity	5% ~ 95% (Non-condensing)
Storage Temperature (°C)	-15~60
Net Weight (kg)	95kg
Gross Weight (kg)	105kg
Dimensions (H*W*D) (mm)	870×415×309mm
Packaging Dimensions (H*W*D) (mm)	920×465×349mm
Max. Operating Altitude (m)	4000 (Derating above 2000)

Wall-mounted household energy storage battery — 25.6V 200Ah



Product Highlights

The system boasts high energy density and high charge/discharge conversion efficiency; it features a built-in BMS battery management system with multiple safety protections; the system structure is flexible and reliable, supporting expansion and upgrades; and its highly modular design results in a simple structure that is easy to install and maintain.

Core advantages

Small in size, large in capacity, easy to move, and supports up to 15 groups of parallel expansion to meet different capacity requirements.

Application scenarios

Suitable for home energy storage applications such as small-capacity grid-connected equipment, low-power household appliances, mains backup power systems, and home emergency backup power.

Product Features

01

Supports up to 15 units in parallel for expansion

02

Support main-stream inverters in the market

03

LCD display, easy to view battery operation data

04

Built-in advanced battery protection module, safe and efficient operation

Product Specifications

Project	Parameter
Model	LD-WLFP25.6-200Ah
Power	5.12 KWh
Rated capacity	200Ah
Cell type	LiFePO4
Cycle life	>6000 cycles
Nominal voltage	25.6V
Discharge cut-off voltage	22.4 V
Charging cut-off voltage	29.2 V
Battery continuous charge and discharge current	100A
Maximum charge and discharge current	200A
Display Mode	LCD Display
Cooling method	Natural air cooling
Size (W x D x H)	375*180*600mm
Packaging dimensions (W×D×H)	475*280*700mm
Net weight	45.7kg
Gross weight	48.7kg
Installation type	Wall-mounted
IP Rating	IP21
Operating temperature	-20°C to 60°C
Communication methods	CAN/RS485/RS232
Communication Protocol	PYL/GRO
Service life	≥10 years

Floor-standing household energy storage battery – 48V 225Ah and 48V 314Ah



Product Highlights

The system boasts high energy density and high charge/discharge conversion efficiency; it features a built-in BMS battery management system with multiple safety protections; the system structure is flexible and reliable, supporting expansion and upgrades; and its highly modular design results in a simple structure that is easy to install and maintain.

Core advantages

Small in size, large in capacity, easy to move, and supports up to 15 groups of parallel expansion to meet different capacity requirements.

Application scenarios

Suitable for home energy storage applications such as small-capacity grid-connected equipment, low-power household appliances, mains backup power systems, and home emergency backup power.

Product Features

01

Supports up to 15 units in parallel for expansion

02

Support main-stream inverters in the market

03

LCD display, easy to view battery operation data

04

Built-in advanced battery protection module, safe and efficient operation

Product Specifications

Project	Parameter	
Model	LD-FSLFP48V-225	LD-FSLFP48V-314
Power	10.8 KWh	15.072 KWh
Rated capacity	225 Ah	314Ah
Cell type	LiFePO4	
Cycle life	>6000 cycles	
Nominal voltage	48V	
Discharge cut-off voltage	42V	
Charging cut-off voltage	54.7V	
Battery continuous charge and discharge current	112.5A	157A
Maximum charge and discharge current	225A	314A
Display Mode	LCD Display	
Cooling method	Natural air cooling	
Size (W x D x H)	367x276x846mm	460x281x1020mm
Packaging dimensions (W×D×H)	430x340x1005mm	524x345x1180mm
Net weight	88.5kg	131kg
Gross weight	100kg	145kg
Installation type	Floor-standing/Pulley	
IP Rating	IP21	
Operating temperature	-20°C to 60°C	
Communication methods	CAN/RS485/RS232	
Communication Protocol	PYL/GRO	
Service life	≥10 years	

Monocrystalline Solar Panel

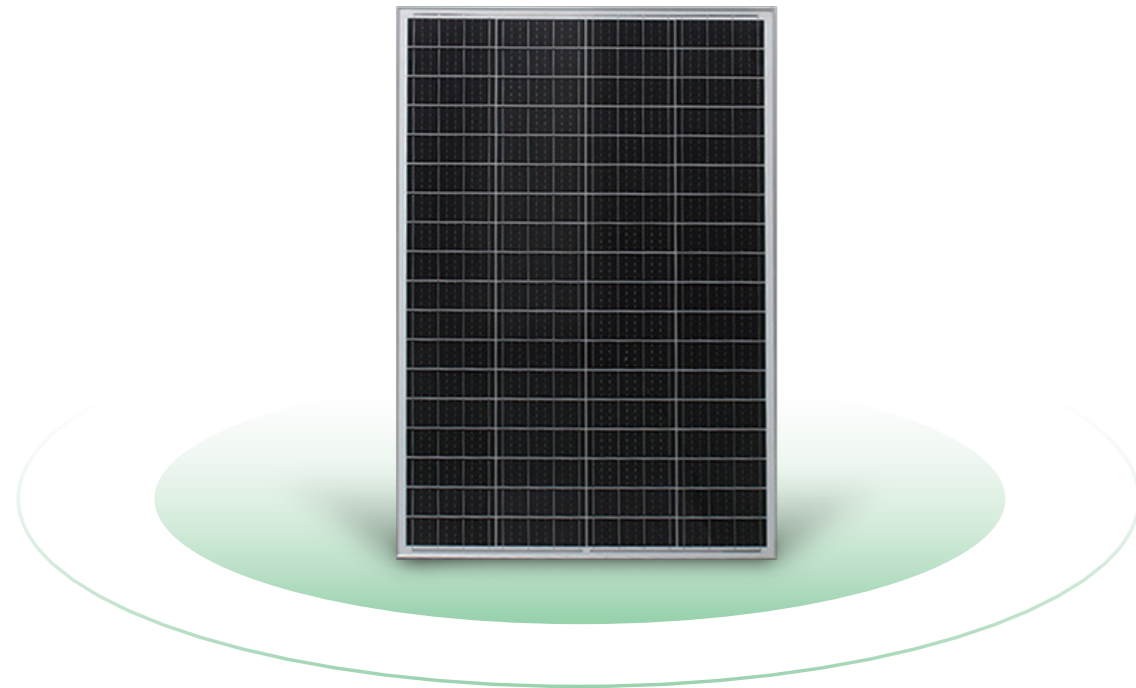

Product Features

01

Modules can withstand snow pressure up to 5400Pa and wind pressure up to 2400Pa

02

Guaranteed output power (0~+3%)

03

High performance in low light conditions, cloudy weather, early morning, evening, etc.

04

100% EL testing is performed before and after lamination, as well as EL-IV testing of finished products to provide higher quality assurance.

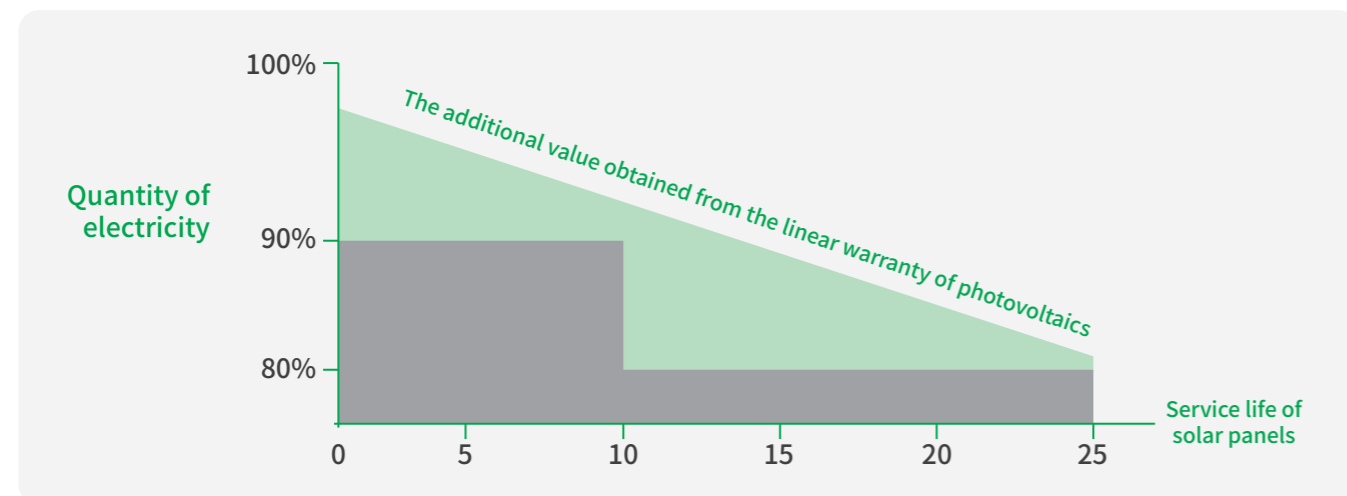

Product Specifications

Project	Technical parameters				
Model	LD-N-100	LD-N-150	LD-N-200	LD-N-250	LD-N-300
Maximum power—pmax (wp)	100W	150W	200W	250W	300W
Power tolerance—pmax (%)	0/+3				
Working voltage—vmp (V)	18			19	30
Operating current—imp (A)	5.55	8.33	11.11	13.1	10
Open circuit voltage—voc (V)	23.4			25.6	36
Short circuit current—isc (A)	6.11	9.16	12.22	14.4	11.2
Cell efficiency ηm (%)	22				
Measured value power test error under standard test conditions (air quality AM1.5, irradiance 1000W/m ² , battery temperature 25°C): ±3%					
Solar cells	182x182mm monocrystalline silicon			210x210mm monocrystalline silicon	
Component size	580*930*30 mm	1070*780*30 mm	1400*780*30 mm	875*1535*30 mm	1650*880*35 mm
Weight	4.6kg	8.08kg	10.14kg	13.5kg	14.5kg
Glass	3.0mm high transmittance solar glass			3.2mm high transmittance solar glass	
Frame	anodized aluminum				
Junction box	Protection class IP 65				
Packing size	595*945*135 mm	1080*790*75 mm	1410*790*75 mm	1350*890*90 mm	1660*890*90 mm
Packing quantity	4 tablets per box	2 tablets per box	2 tablets per box	2 tablets per box	2 tablets per box
Net weight	18.4kg	16.16kg	20.54kg	27kg	29kg
Gross weight	20.4kg	17.61kg	21.02kg	29.2kg	31kg
Working temperature	-40~+85°C				
Maximum system voltage	1000VDC(IEC) 600VDC(UL)				
Maximum fuse rated current	10A	13A	17A	22A	15A

N-type cell monocrystalline panel

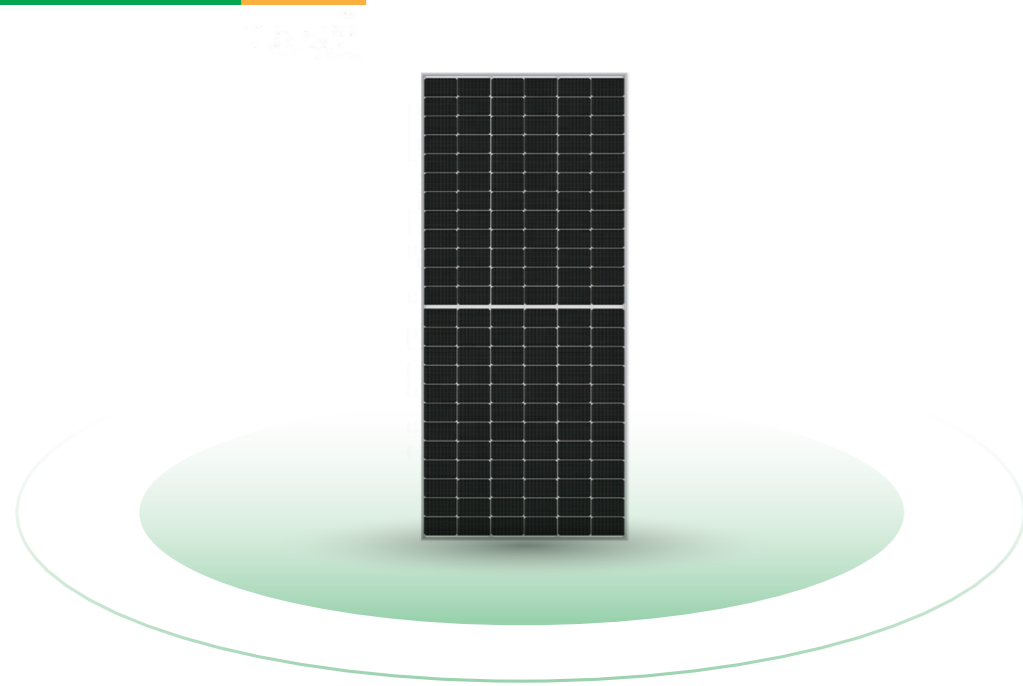

01

Anti-PID, it can meet the highest standards in harsh environments

02

Multi-grid technology for better power output in low light conditions

03

Excellent resistance to microcracks, more balanced internal stress

Product Specifications

Project	Parameter
Model	LD-N-580
Maximum power	580W
Optimum operating voltage	43.85V
Optimum operating current	13.24A
Open circuit voltage	52.5V
Short circuit current	13.99A
Module efficiency	22.5%
Cell type	N-type monocrystalline cell
Component size	2278*1134*30mm
Weight	31.8kg
Output wire	TUV1*4mm ²

Temperature Characteristics

Project	Parameter
Nominal Module Operating Temperature (NMOT)	42±2°C
Temperature Coefficient of Pmax (%/°C)	-0.29
Temperature Coefficient of Voc (%/°C)	-0.25
Temperature Coefficient of Isc (%/°C)	0.048

Packaging

Project	Parameter
Container	40HQ
Pallet Dimensions (mm)	2320×1140×1250
Pieces per Pallet	36
Pieces per Container	720

Operating Conditions

Project	Parameter
Operating Temperature (°C)	-40 to +85
Maximum System Voltage (V)	1500 DC (IEC)
Overcurrent Protection Rating (A)	30
Power Output Tolerance (%)	0~3
Protection Class	Class II
Max. Test Load, Push/Pull (Pa)	Front 5400 / Back 2400
Max. Design Load, Push/Pull (Pa)	Front 3600 / Back 1600

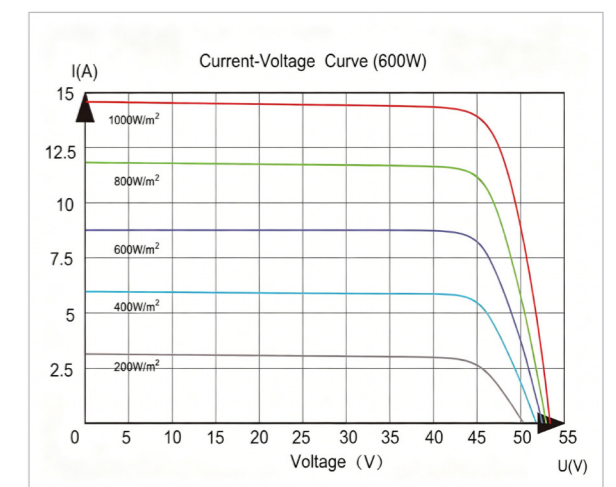

LiFePO4 Battery



Product Features

Utilizing lithium iron phosphate (LiFePO₄) cells and an intelligent BMS battery management system, this product directly replaces traditional lead-acid batteries. It boasts a longer lifespan, greater usable capacity, lighter weight, and a more compact size. The built-in multi-layered safety protection BMS system effectively ensures charging and discharging safety and system stability.

This product is widely used in residential solar power systems, UPS uninterruptible power supplies, inverter energy storage systems, as well as in RVs, yachts, mobile energy storage, and emergency power supplies.

Product Features

01

Long lifespan and extremely low self-discharge rate

02

Ample capacity, higher energy density

03

Higher charge and discharge efficiency, larger usable capacity

04

Built-in intelligent BMS with multiple security protections

Product Specifications

Project	Technical parameters			
Rated voltage	12.8V		25.6V	
Operating voltage	10V~14.6V		20V~29.2V	
Nominal capacity	100Ah	200Ah	100Ah	200Ah
Battery	1280Wh	2560Wh	2560Wh	5120Wh
Positive electrode material of battery cell	LiFePO ₄			
Cell type	Square			
Cycle life	>5000次			
Recommended charging current	≤50A	≤100A	≤50A	≤100A
Charging upper limit voltage	14.6V	14.6V	29.2V	29.2V
Charging temperature range	-20~60°C			
Maximum continuous discharge current	100A	200A	100A	200A
Maximum discharge current 170ms	400A@170ms	600A@170ms	400A@170ms	600A@170ms
Discharge lower limit voltage	9.6V	9.6V	19.2V	19.2V
BMS voltage recovery	10.4V	10.4V	10.4V	10.4V
Discharge temperature range	-20~60°C			
L*W*H size	330*172*215mm	483*170*240mm	483*170*240mm	522*238*218mm
weight	10.6kg	23kg	23kg	41kg
Charging voltage	Floating charge: 13.35V~13.5V Equalizing charge: 14~14.6V		Floating charge: 13.35V~13.5V Equalizing charge: 14~14.6V	
Terminal	M8			
Shell material	ABS			
Temperature on capacity	40°C	106%		
	25°C	100%		
	0°C	86%		
Self discharge	≤3%/month @25°C			